

EN OWNER'S MANUAL /

Instructions for Assembly '7 Ft Store Max Plus'
Size 7Ft x 7Ft / 2.1 m x 2.1 m (Approx.)
Ver: 2.0

FR MANUEL D'INSTRUCTION/

Instructions pour l'Assemblage '7 Pieds Store Max Plus'
Dimension 7Pieds x 7Pieds / 2.1 Mètre x 2.1 Mètre (Approx.)
Ver: 2.0

DE Benutzerhandbuch /

Montageanleitung '7 Ft Store Max Plus'
Größe: 7Ft x 7Ft / 2.1 m x 2.1 m (Ca.)
Ver: 2.0

ES MANUAL DEL PROPIETARIO /

Instrucciones de montaje '7 Pies Store Max Plus'
Tamaño 7Pies x 7Pies / 2.1 Metros x 2.1 Metros (Aprox.)
Ver: 2.0

PT MANUAL DO PROPRIETARIO/

Instruções de montagem '7 pés Store Max Plus'
Tamanho 7pés x 7pés / 2.1 Metro x 2.1 Metro (Aprox.)
Ver: 2.0

NL Gebruiksaanwijzing voor eigenaar/

Instructies voor bouw '7Voet Store Max Plus'
Maat 7 voet x 7 voet / 2.1 Meter x 2.1 Meter (Ongeveer)
Versie: 2.0

CS Příručka uživatele /

Návod k montáži '7 Stopy Store Max Plus'
Velikost 7 Stopy x 7 Stopy / 2.1 Metr x 2.1 Metr (Přibližně)
Verze : 2.0

SK NÁVOD PRE UŽÍVATEĽA /

Návod na zloženie '7 Stopa Store Max Plus'
Veľkosť 7Stopa x 7Stopa / 2.1 m x 2.1 m (približne)
Pozri: 2.0

SL PRIROČNIK ZA LASTNIKA /

Navodila za montažo '7 Čevljev Store Max Plus'
Velikost 7Čevljev x 7Čevljev / 2.1 Metrov x 2.1 Metrov (Približno)
Razl: 2.0

HR Gazdinski Priručnik /

Instrukcije za skupštine '7 Stopalo Store Max Plus'
Veličina 7 Stopalo x 7 Stopalo / 2.1 Metar x 2.1 Metar (Približno)
Ver: 2.0

HU FELHASZNÁLÓI KÉZIKÖNYV /

Utmutató az összeszereléshez '7 Láb Store Max Plus'
7Láb x 7Láb / 2.1 Méter x 2.1 Méter (Hozzávetőlegesen)
Verzió: 2.0

SV ÄGARENS MANUAL/

Monteringsinstruktioner för '7 Fot Store Max Plus'
Storlek 7 fot x 7 fot / 2.1 m x 2.1 m (Ungefär)
Version: 2.0

IT MANUALE DEL PROPRIETARIO /

Istruzioni per l'assemblaggio '7 Piedi Store Max Plus'
Dimensione 7 Piedi x 7 Piedi / 2.1Metri x 2.1Metri (Circa)
Versione 2.0

PL PODRĘCZNIK UŻYTKOWNIKA /

Instrukcja montażu '7 Stopy Store Max Plus'
Wymiary 7Stopy x 7Stopy / 2.1 Metr x 2.1 Metr (W przybliżeniu)
Wersja: 2.0

RO MANUAL DE UTILIZARE /

Instrucțiuni de asamblare '7 Picioare Store Max Plus'
Mărimē 7Picioare x 7Picioare / 2.1 Metri x 2.1 Metri (Aprox.)
Ver: 2.0

BG РЪКОВОДСТВО ЗА ПРИТЕЖАТЕЛЯ /

Инструкции за сглобяване '7 Фута Store Max Plus'
Размер 7 Фута x 7 Фута / 2.1 Метра x 2.1 Метра (приблизително)
Версия: 2.0

TR KULLANIM KILAVUZU /

Montaj Talimatları '7 Fit Store Max Plus'
7Fit x 7Fit / 2.1 m x 2.1m (Yaklaşık olarak)
Sürüm: 2.0

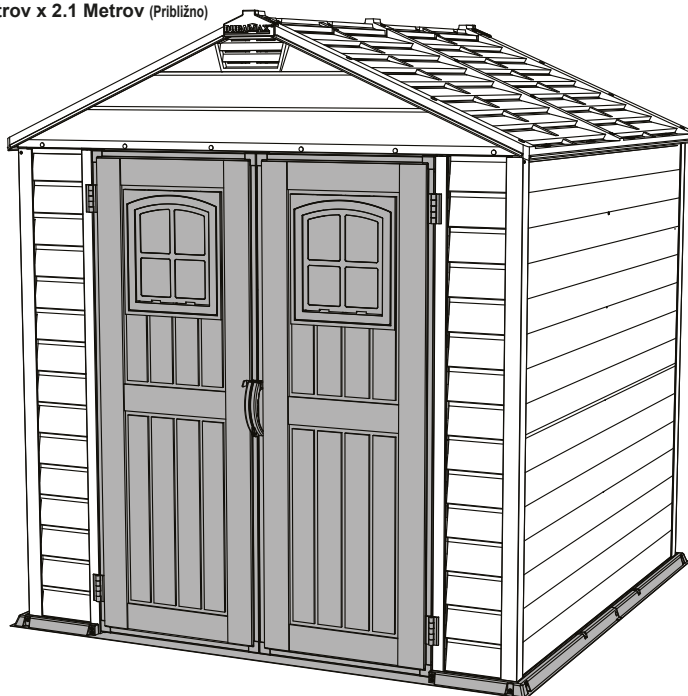
**Model # 30325-3**

EN

Building Dimensions :

Approximate Size	Storage		Exterior Dimension				Interior Dimension		Door Opening		
	Area	Volume	Base Dimension		Roof Edge to Edge		Wall to Wall				
			inch	cm	inch	cm	inch	cm	inch	cm	
7 Ft x 7 Ft	41 Sq. Ft	245.4 Cu.Ft	Width	82 7/8	210.6	81 1/2	207	76 3/4	195	53 1/4	135.4
2.1 m x 2.1 m	3.8 Sq.m	6.95 Cu.m	Depth	82 7/8	210.6	82 1/4	209	76 3/4	195		
			Height			91 1/2	232.5	72	183	70 7/8	180

Snow load tested max. 20lbs / sq.foot (As per IP Standard).

"We recommend to clear snow from the Roof top after each Snowfall."

A snow depth of more than 10cm can become hazardous!

FR

Dimensions du bâtiment :

Taille approximative	Stockage		Dimension extérieure				Dimension intérieure		Ouverture de porte		
	Secteur	Volume	Dimension de base		Toit de bord au bord		Mur à mur				
			pouce	cm	pouce	cm	pouce	cm	pouce	cm	
7 Pieds x 7 Pieds	41 Carré pieds	245.4 Pieds cube	Largeur	82 7/8	210.6	81 1/2	207	76 3/4	195	53 1/4	135.4
2.1 Mètre x 2.1 Mètre	3.8 Mètre carré	6.95 Mètre cube	Profondeur	82 7/8	210.6	82 1/4	209	76 3/4	195		
			Hauteur			91 1/2	232.5	72	183	70 7/8	180

Charge de neige testé max. 20lbs / Carré pieds (conformément à la norme IP)

"Nous recommandons d'enlever la neige du Toit après chaque Enneigement."

Une épaisseur de neige de plus de 10cm peut devenir dangereux!

DE

Gebäude Abmessung:

Ungefähre Größe	Speicher		Außen Abmessung				Innen Abmessung		Türöffnung		
	Bereich	Volumen	Fundament Abmessung		Dach Kante bis Kante		von Wand zu Wand				
			inch	cm	inch	cm	inch	cm	inch	cm	
7 Ft x 7 Ft	41 Sq. Ft	245.4 Cu.Ft	Breite	82 7/8	210.6	81 1/2	207	76 3/4	195	53 1/4	135.4
2.1 m x 2.1 m	3.8 Sq.m	6.95 Cu.m	Tiefe	82 7/8	210.6	82 1/4	209	76 3/4	195		
			Höhe			91 1/2	232.5	72	183	70 7/8	180

Schneelast max. getestet. 20lbs /sq.Foot (gem. Standard IP).

"Wir empfehlen liegenden Schnee nach jedem Schneefall vom Dach abzuräumen."

Eine Schneetiefe von mehr als 10cm kann gefährlich werden!

ES

Medidas de la caseta:

El Tamaño a aproximado	Área de almacenaje		Dimensión exterior				Dimensión interior		Abertura de la puerta		
	Área	Volumen	Dimensión de la base		Borde de la azotea al borde		pared a pared				
			Pulgada	cm	Pulgada	cm	Pulgada	cm	Pulgada	cm	
7 Pies x 7Pies	41 Pies cuadrados	245.4 Pies cúbicos	Anchura	82 7/8	210.6	81 1/2	207	76 3/4	195	53 1/4	135.4
2.1 Metros x 2.1 Metros	3.8 Metros cuadrados	6.95 Metros Cúbicos	Profundidad	82 7/8	210.6	82 1/4	209	76 3/4	195		
			Altura			91 1/2	232.5	72	183	70 7/8	180

Carga de nieve probado max. 20lbs / Pies cuadrados (según el estándar de IP).

"Se recomienda limpiar la nieve de la azotea después de cada nevada."

Una profundidad de nieve de más de 10cm puede llegar a ser peligrosa!

PT

Área de Construção:

Dimensão aproximada	Área de Arrumação		Dimensão Exterior				Dimensão Interior		Abertura da Porta		
	Área	Volume	Dimensão da base		Amplitude do Telhado		(Parede a Parede)				
			Polegada	centímetro	Polegada	centímetro	Polegada	centímetro	Polegada	centímetro	
7 pés x 7 pés	41 Pies quadrado	245.4 Pies cúbico	Comprimento	82 7/8	210.6	81 1/2	207	76 3/4	195	53 1/4	135.4
2.1 Metro x 2.1 Metro	3.8 Metro quadrado	6.95 Metro cúbico	Profundidade	82 7/8	210.6	82 1/4	209	76 3/4	195		
			Altura			91 1/2	232.5	72	183	70 7/8	180

Carga de neve testado max. 20lbs / Pies quadrado (conforme padrão IP).

"Recomendamos limpar a neve do topo do telhado após cada queda de neve."

Uma profundidade de neve de mais de 10cm pode tornar-se perigosa!

NL

Gebouw afmeting:

Benadering Maat	Opslag		Buitenkant afmeting				Binnenkant afmeting		Deur opening		
	Gebied	Volume	Basis afmeting		Dakrand tot rand		Muur tot muur				
			inch	cm	inch	cm	inch	cm	inch	cm	
7 Voet x 7 Voet	41 Vierkante voet	245.4 Kubieke voet	Wijde	82 7/8	210.6	81 1/2	207	76 3/4	195	53 1/4	135.4
2.1 m x 2.1 m	3.8 Vierkante meter	6.95 Kubieke meter	Diepte	82 7/8	210.6	82 1/4	209	76 3/4	195		
			Hoogte			91 1/2	232.5	72	183	70 7/8	180

Sneeuw belasting getest max. 20lbs / Vierkante voet (volgens het standaard IP-).

“We raden aan sneeuw uit het dak te verwijderen na elke sneeuwval.”

Een sneeuwdiepte van meer dan 10 cm kan gevaarlijk worden!

CS

Budova rozměr

Přibližné rozměry	Skladování		Vnější rozměr				Vnitřní rozměr		Otevírání dveří		
	Plocha	Objem	Základní rozměr		Na okraj střechy edge		zdi ke zdi				
			inch	cm	inch	cm	inch	cm	inch	cm	
7 Stopy x 7 Stopy	41 Čtvereční Stopy	245.4 Krychlový Stopy	Šířka	82 7/8	210.6	81 1/2	207	76 3/4	195	53 1/4	135.4
2.1 Metr x 2.1 Metr	3.8 Čtvereční metr	6.95 Krychlový Metr	Hloubka	82 7/8	210.6	82 1/4	209	76 3/4	195		
			Výška			91 1/2	232.5	72	183	70 7/8	180

Zkouška zatížení sněhu max. 20lbs / Čtvereční Stopy (podle normy IP).

“Doporučujeme odstranit sníh ze střešního krytu po každém sněžení.”

Možná hloubka sněhu větší než 10 cm může být nebezpečná!

SK

Stavebné rozmer

Približné veľkosti	Sklad		Vonkajší rozmer				Interiér rozmer		Otvorenie dverí		
	Priestor	Objem	Base rozmer		Strešné okraja k okraju		Zdi k múru				
			inch	cm	inch	cm	inch	cm	inch	cm	
7 Stopa x 7 Stopa	41 Stopa štvorcový	245.4 Stopa kubický	Šírka	82 7/8	210.6	81 1/2	207	76 3/4	195	53 1/4	135.4
2.1 m x 2.1 m	3.8 Meter štvorcový	6.95 Meter kubický	Hĺbka	82 7/8	210.6	82 1/4	209	76 3/4	195		
			Výška			91 1/2	232.5	72	183	70 7/8	180

Testovanie zaťaženia snehu max. 20lbs / Stopa štvorcový (podľa IP štandardu).

“Odporúčame odstrániť sneh zo strechy po každej snehu.”

Z hĺbky snehu väčšej ako 10 cm sa môže stať nebezpečné!

SL

Zidanje obseg

približno velikost	Skladiščenje		zunanji obseg				notranji obseg		vrata predrtina		
	Območje	Prostornina	osnova obseg		streha rob v rob		obdati obzidati				
			cola	cm	cola	cm	cola	cm	cola	cm	
7 Čevljev x 7 Čevljev	41 Kvadratnih Čevljev	245.4 Kubičnih Čevljev	širina	82 7/8	210.6	81 1/2	207	76 3/4	195	53 1/4	135.4
2.1 Metrov x 2.1 Metrov	3.8 Kvadratnih Metrov	6.95 Kubičnih Metrov	globina	82 7/8	210.6	82 1/4	209	76 3/4	195		
			višina			91 1/2	232.5	72	183	70 7/8	180

Snow obremenitev testiran max. 20lbs / Kvadratnih Čevljev (po standardu IP).

“Priporočamo, da počistite sneg z vrha strehe po vsakem sneženju.”

Z globino snega več kot 10 cm lahko postane nevarno!

HR

Zgrada dimenzija

Približno određena mjera	Skladištenje		Vanjski dimenzija				Interijer dimenzija		Vrata Open		
	Područje	Svezak	Temeljiti dimenzija		Krov rub to rub		Zidni to zidni				
			inch	cm	inch	cm	inch	cm	inch	cm	
7 Stopalo x 7 Stopalo	41 Četvornih Stopalo	245.4 Kubni Stopalo	širina	82 7/8	210.6	81 1/2	207	76 3/4	195	53 1/4	135.4
2.1 Metar x 2.1 Metar	3.8 Četvornih Metar	6.95 Kubni Metar	dubina	82 7/8	210.6	82 1/4	209	76 3/4	195		
			visina			91 1/2	232.5	72	183	70 7/8	180

Testirano opterećenje max.20lbs / Četvornih Stopalo (prema IP standardu).
 “Preporučujemo čišćenje snijega s vrha krova nakon svakog snijega.”
 Nema dubine snijega veće od 10 cm može biti opasna!

HU

Építési dimenzió

Hozzávetőleges mérete	Tárolás		Külső méret				A belső dimenzió		Ajtónyitítás		
	Terület	Mennyiség	Alap dimenzió		Tető élétől él		A fal és a fal				
			Hüvelyk	cm	Hüvelyk	cm	Hüvelyk	cm	Hüvelyk	cm	
7 Láb x 7 Láb	41 Négyzet Láb	245.4 Kőb Láb	Szélesség	82 7/8	210.6	81 1/2	207	76 3/4	195	53 1/4	135.4
2.1 Méter x 2.1 Méter	3.8 Négyzet méter	6.95 Köbméter	Oldalmagasság	82 7/8	210.6	82 1/4	209	76 3/4	195		
			Magasság			91 1/2	232.5	72	183	70 7/8	180

A terhelés max. 20lbs / Négyzet Láb (IP-szabvány szerint).
 “Javasoljuk, hogy minden hóesést követően tisztítsa meg a havat a tetőtől.”
 A 10 cm-nél hosszabb hóvastagság veszélyessé válhat!

SV

Byggnadsdimensioner:

Ungefärlig storlek	Lager		Yttre dimensioner				Inre dimensioner		Dörröppning		
	Area	Volym	Basdimensioner		Tak kant till kant		Vägg till vägg				
			Tum	cm	Tum	cm	Tum	cm	Tum	cm	
7 fot x 7 fot	41 kvadrat fot	245.4 kubik fot	Bredd	82 7/8	210.6	81 1/2	207	76 3/4	195	53 1/4	135.4
2.1 m x 2.1 m	3.8 kvadratmeter	6.95 kubik meter	Djup	82 7/8	210.6	82 1/4	209	76 3/4	195		
			Höjd			91 1/2	232.5	72	183	70 7/8	180

Snow last testas max. 20lbs / kvadrat fot (enligt IP-standard).
 “Vi rekommenderar att klara snö från taket efter varje snöfall.”
 Ett snödjup på mer än 10 cm kan bli farligt!

IT

Dimensioni di Costruzione:

Dimensione approssimativa	Deposito		Dimensione Esterna				Dimensioni Interne		Apertura della Porta		
	Area	Volume	Dimensione della Base		Soffitto da Lato a Lato		Da Muro a Muro				
			Inches	Centimetri	Inches	Centimetri	Inches	Centimetri	Inches	Centimetri	
7 Piedi x 7 Piedi	41 Piedi Quadrati	245.4 Piedi Cubici	Ampiezza	82 7/8	210.6	81 1/2	207	76 3/4	195	53 1/4	135.4
2.1 Metri x 2.1 Metri	3.8 Metri Quadrati	6.95 Metri Cubici	Profondità	82 7/8	210.6	82 1/4	209	76 3/4	195		
			Altezza			91 1/2	232.5	72	183	70 7/8	180

Snow carico testato max. 20lbs / Piedi Quadrati (come per IP standard).
 “We consigliamo di eliminare la neve dalla tetto del tetto dopo ogni nevicata.”
 Una profondità di neve di oltre 10 cm può diventare pericolosa!

PL

Wymiary budowlane:

Przybliżone wymiary	Magazynowa		Wymiary zewnętrzne				Wymiary wewnętrzne		Otwieranie drzwi		
	Powierzchnia	Kubatura	Wymiary fundamentów		Dachu od krawędzi do krawędzi		od ściany do ściany				
			Cal	cm	inch	cm	inch	cm	inch	cm	
7 Stopy x 7 Stopy	41 Stopy kwadratowy	245.4 Stopy sześcienny	Szerokość	82 7/8	210.6	81 1/2	207	76 3/4	195	53 1/4	135.4
2.1 Metr x 2.1 Metr	3.8 Metr kwadratowy	6.95 Metr sześcienny	Głębokość	82 7/8	210.6	82 1/4	209	76 3/4	195		
			Wysokość			91 1/2	232.5	72	183	70 7/8	180

Testowane obciążenie śniegiem max. 20lbs (zgodnie ze standardem IP).
 “Po każdym opadzie śniegu zalecamy usuwanie śniegu z dachu”.
 Grubość śniegu powyżej 10 cm może być niebezpieczna!

RO

Cladirea dimensiuni

Dimensiunea aproximativa	Depozitarea		Dimensiunea exterioara				Dimensiunea interne		deschiderea usii		
	Suprafata	Volumul	Baza dimensiuni		Acoperisul marginea la marginea		perete in perete				
			inch	cm	inch	cm	inch	cm	inch	cm	
7 Picioare x 7 Picioare	41 Picioare pătrați	245.4 Picioare cubi	Latimea	82 7/8	210.6	81 1/2	207	76 3/4	195	53 1/4	135.4
2.1 Metri x 2.1 Metri	3.8 Metri pătrați	6.95 Metri cubi	Adancimea	82 7/8	210.6	82 1/4	209	76 3/4	195		
			Inaltimea			91 1/2	232.5	72	183	70 7/8	180

Rezultatea de încărcare maximă testată. 20lbs / Picioare pătrați (conform standardului IP).
 “Vă recomandăm să eliminați zăpada din partea superioară a acoperișului după fiecare zăpadă.”
 O adâncime de zăpadă mai mare de 10 cm poate deveni periculoasă!

BG

Сградата измерение

Ориентировачна размер	Съхранение		Външно измерение				Министърът на вътрешните измерение		Вратата отваряне		
	Площ	Обем	База измерение		Покрив край до край		Стената на стената				
			Инча	Сантиметра	Инча	Сантиметра	Инча	Сантиметра	Инча	Сантиметра	
7 Фута x 7 Фута	41 Квадратни Фута	245.4 Кубични Фута	Ширина	82 7/8	210.6	81 1/2	207	76 3/4	195	53 1/4	135.4
2.1 Метра x 2.1 Метра	3.8 Квадратни Метра	6.95 Кубични Метра	Дълбочина	82 7/8	210.6	82 1/4	209	76 3/4	195		
			Височина			91 1/2	232.5	72	183	70 7/8	180

Тестване на тежестта на снемане макс. 20lbs / Квадратни Фута (според IP Стандарт).
 “След всеки снеговалеж препоръчваме да изчистите снега от покрива на покрива.”
 Дълбочина на снега повече от 10 см може да стане опасна!

TR

İnşaat boyutu

Tahmini büyüklüğü	Depo		Dış boyutlar				İç boyutu		Kapı açılması		
	Alan	Hacim	Temel boyutundaki		sertliği için harekete		Duvardan duvara				
			İnç	Santimetre	İnç	Santimetre	İnç	Santimetre	İnç	Santimetre	
7 Fit x 7 Fit	41 Metre Fit	245.4 Kübik Fit	Genişlik	82 7/8	210.6	81 1/2	207	76 3/4	195	53 1/4	135.4
2.1 m x 2.1 m	3.8 Metrekare	6.95 Kübik metre	Derinlik	82 7/8	210.6	82 1/4	209	76 3/4	195		
			Yükseklik			91 1/2	232.5	72	183	70 7/8	180

Saat yükü test max. 20lbs / Metre Fit (IP Standardına göre).
 “Her Kar yağışı sonrasında Çatı üstten kar temizlemenizi öneririz.”
 Kar derinliği 10 cm'den fazla tehlikeli olabilir!

EN Tools You Will Need

- | | |
|----------------------------------|-----------------------------|
| 1. Cordless Drill - Philips Head | 6. Tape Measure |
| 2. Screwdriver - Philips Head | 7. Hand Gloves |
| 3. Carpenters Square | 8. Eye Protector |
| 4. 8' Step Ladder | 9. Waterproof Clear Silicon |
| 5. Level - 3ft. | 10. Hammer or Rubber mallet |

FR Outils dont vous aurez besoin

- | | |
|-------------------------------------|-----------------------------------|
| 1. Perceuse sans fil – Tête Philips | 6. Ruban à mesurer |
| 2. Tournevis - Tête Philips | 7. Gants |
| 3. Équerre du Menuisier | 8. Protecteur des Yeux |
| 4. Escabeau 8' | 9. Silicone neutre étanche |
| 5. Niveau - 3ft. | 10. Marteau ou maillet caoutchouc |

DE Benötigte Werkzeuge

- | | |
|---|---------------------------------|
| 1. Akku-Bohrschrauber - Kreuzschlitzbit | 6. Maßband |
| 2. Kreuzschlitz-Schraubenzieher | 7. Handschuhe |
| 3. Winkelmaß | 8. Schutzbrille |
| 4. 8' Leiter | 9. Wasserdichtes klares Silikon |
| 5. Wasserwaage – 1 m | 10. Hammer oder Gummihammer |

ES Herramientas necesarias para el montaje

- | | |
|--|--|
| 1. Atornillador eléctrico con cabeza estrella- | 6. Cinta métrica |
| 2. Destornillador estrella / Philips | 7. Use guantes de seguridad |
| 3. Gafas protectoras | 8. Escuadra |
| 4. Escalera de 8 peldaños | 9. Silicio transparente a prueba de agua |
| 5. Nivel de 1m | 10. Martillo o mazo de goma |

PT Ferramentas que irá precisar

- | | |
|------------------------------------|--------------------------------------|
| 1. Cordless Berbequim | 6. Fita Métrica |
| 2. Chave de fenda – cabeça estrela | 7. Luvas |
| 3. Esquadro de carpinteiro | 8. Protector Ocular |
| 4. Escadote 8' | 9. Silicone Transparente Impermeável |
| 5. 3ft. Nível | 10. martelo ou malho de borracha |

NL Gereedschappen die u nodig zult hebben

- | | |
|---|------------------------------|
| 1. Snoerloze boormachine met gekruiste kop | 6. Meetlint |
| 2. Snoerloze schroevendraaier met gekruiste kop | 7. Handschoenen |
| 3. Winkelhaak | 8. Oogbescherming |
| 4. Ladder met acht treden | 9. Waterdicht Clear Silicone |
| 5. Waterpas | 10. Hamer of rubberen hamer |

CS Budete potřebovat toto nářadí

- | | |
|---------------------------------|----------------------------|
| 1. Bezdrátová vrtačka - Philips | 6. Svinovací metr |
| 2. Vrták - Philips | 7. Rukavice |
| 3. Tesařské náměstí | 8. Ochranné brýle |
| 4. 8mí stupňový žebřík | 9. Vodotěsný čistý silikon |
| 5. Vodováha - 3ft. | 10. Kladivo nebo kaučuk |

SK Nástroje, ktoré budete potrebovať

- | | |
|--------------------------------------|----------------------------------|
| 1. Bezdrôtová vrtačka - Philips Head | 6. Meter |
| 2. Šraubovák – Philips Head | 7. Rukavice |
| 3. Stolársky meter | 8. Ochrana na oči |
| 4. 8' Rebrík | 9. Vodotesný čistý silikón |
| 5. Zdvihák – 3 stopy. | 10. Kladivo alebo gumená palička |

SL Orodje, ki ga boste potrebovali

- | | |
|-----------------------------------|-----------------------------------|
| 1. Brežična vrtalna- glava Philip | 6. Merilni trak |
| 2. Vijačnik-glava Philip | 7. Rokavice |
| 3. Mizarski kvadrat | 8. zaščitna očala |
| 4. 2438,4 mm dvokraka lestev | 9. Vodoodporni Clear Silikon |
| 5. Nivelirka - 0,91 m | 10. Kladivo za kladivo ali kavčuk |

HR Alati, Trebat će Vam

- | | |
|--------------------------------------|----------------------------------|
| 1. Bežični Svrdlo – Philips Voditelj | 6. Traka Divizor |
| 2. Vijak Vozač - Philips Voditelj | 7. Ručni Rukavice |
| 3. Drvodjelac Četverkut | 8. Oko Zaštitnik |
| 4. 8' Korak Ljestve | 9. Vodonepropusni bistri silikon |
| 5. Razina – 3 stoplo. | 10. Čekić ili gumeni čekić |

HU A szükséges szerszámok

- | | |
|---------------------------------------|-----------------------------|
| 1. Vezeték nélküli fúró – csillagfejű | 6. Mérőszalag |
| 2. Csavarhúzó – csillagfejű | 7. Kesztyűk |
| 3. Ácsderékszög | 8. Szemvédő |
| 4. 8-fokú létra | 9. Vízálló, tiszta szilikon |
| 5. Vízszintmérő. | 10. Hammer vagy gumi sisak |

SV Verktyg du kommer att behöva

- | | |
|--------------------------------------|-------------------------------|
| 1. Sladdlös bormaskin - Philips borr | 6. Måttband |
| 2. Skruvmejsel - krysshuvud | 7. Verktygshandskar |
| 3. Vinkelhake | 8. Ögonskydd |
| 4. 8-fots stege | 9. Vattentät Klar Silikon |
| 5. vattenmått - 3fot. | 10. Hammer eller Gummihammare |

IT Gli Attrezzi di cui Avrai Bisogno

- | | |
|--|--------------------------------------|
| 1. Trapano senza fili – Punta a stella | 6. Metro a Nastro |
| 2. Cacciavite – Punta a stella | 7. Guanti |
| 3. Squadra metallica | 8. Protezione per gli occhi |
| 4. Scala ad 8 pioli | 9. Silicone trasparente impermeabile |
| 5. Livello – 3 piedi | 10. Martello o martello di gomma |

PL Potrzebne narzędzia

- | | |
|---|--------------------------------------|
| 1. Bezprzewodowa wkrętarka – krzyżakowa | 6. Taśma miernicza |
| 2. Śrubokręt krzyżakowy | 7. Rękawice ochronne |
| 3. Kałownik stolarski | 8. Okulary ochronne |
| 4. 8' Drabina składana | 9. Wodoodporny przezroczysty silikon |
| 5. Poziomica – 91,4 cm | 10. Młotek lub młotek gumowy |

RO Instrumentele de care aveți nevoie

- | | |
|-------------------------------------|------------------------------------|
| 1. Șurubelniță – cap Philips | 6. Ruletă de măsurat |
| 2. Mașină de găurit – cap Philips | 7. Mănuși de protecție |
| 3. Echer de dulgherie | 8. Protecție pentru ochi |
| 4. Scară cu trepte de 8' (20.32 cm) | 9. Silicon transparent impermeabil |
| 5. Nivel - 3ft. | 10. Ciocan sau ciocan din cauciuc |

BG Инструменти, които ще ви трябват

- | | |
|---|------------------------------|
| 1. Безжична бормашина - с глава Philips | 6. Рулетка |
| 2. Отвертка – с глава Philips | 7. Ръкавици |
| 3. Прав ъгъл | 8. Маска за очите |
| 4. Стълба – 20 см (8') | 9. Водоустойчив ясен силикон |
| 5. Нивелир – 1 м (3ft). | 10. Чук или гумен чук |

TR İhtiyaç duyacağınız aletler

- | | |
|------------------------------------|-------------------------------|
| 1. Kablosuz Matkap- Philips Başlık | 6. Mezura |
| 2. Tornavida-Philips Başlık | 7. Eldiven |
| 3. Marangoz gönyesi | 8. Göz Koruyucu |
| 4. 8 Basamaklı Merdiven | 9. Su geçirmez Şeffaf Silikon |
| 5. Seviye- 91,5 cm. | 10. Çekiç veya Kauçuk tokmak |

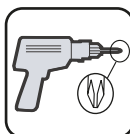

1



2



3



4

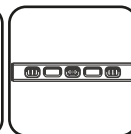

5

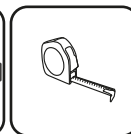

6

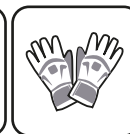

7



8

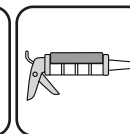

9

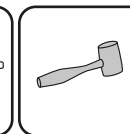

10

EN Parts List	CS Seznam součástí	IT Lista delle varie parti
FR Liste des pièces	SK Zoznam častí	PL Lista części
DE Teilleiste	SL Seznam delov	RO Lista elementelor componente
ES La Lista de Partes	HR Dijelovi Lists	BG Списък на частите
PT Lista de Peças	HU Alkatrésztlista	TR Parça Listesi
NL Onderdelenlijst	SV Komponentlista	

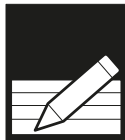
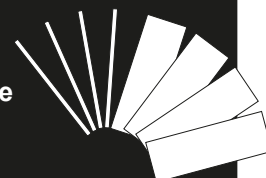

- EN** 1. Check all parts prior to installation.
2. Before starting installation, please refer to Safety & Precautions.

- FR** 1. Vérifier toutes les pièces avant l'installation.
2. Avant de commencer l'installation, référez-vous svp à Sécurité et Précautions.

- DE** 1. Prüfen Sie alle Teile vor der Montage.
2. Lesen Sie vor dem Aufbau die Sicherheitsanweisungen.

- ES** 1. Verifique todo el despiece antes del montaje.
2. Antes de comenzar el montaje, consulte el apartado de seguridad y precauciones.

- PT** 1. Confirme todas as peças antes da instalação.
2. Antes de iniciar a instalação, cheque item "Segurança e Cuidados".

- NL** 1. Controleer vooraf of alle onderdelen aanwezig zijn.
2. Voordat u begint met installeren, verwijzing naar veiligheid voorschriften.

- CS** 1. Něž začnete s montáží, zkontrolujte všechny součásti.
2. Před montáží si prosím přečtete Bezpečnost a bezpečnostní opatření.

- SK** 1. Skontrolujte všetky časti pred inštaláciou.
2. Skôr ako začnete s inštaláciou, prečítajte si Bezpečnosť a bezpečnostné opatrenia.

- SL** 1. Pred montažo preverite vse dele.
2. Pred začetkom namestitve, glejte VARNOST & VARNOSTNI UKREPI.

- HR** 1. Provjera svih dijelova prije instalacije.
2. Prije nego Vi počete instalacija, molim vas pogledajte Sigurnost i mjere opreza

- HU** 1. Ellenőrizzen minden alkatrészt az összeszerelés megkezdése előtt.
2. Az összeszerelés megkezdése előtt kérjük vegye figyelembe a biztonsági utasításokat.

- SV** 1. Kolla alla delar före installationen.
2. innan man startar installationen ska man läsa igenom säkerhet & försiktighetsåtgärder.

- IT** 1. Controlla tutte le parti prima dell'installazione.
2. Prima di incominciare con l'installazione, per favore leggi attentamente I punti illustrati nel paragrafo Sicurezza ed Installazione.

- PL** 1. Sprawdź wszystkie części zanim przystąpisz do montażu.
2. Przed rozpoczęciem instalacji należy przeczytać rozdział Bezpieczeństwo i środki ostrożności.

- RO** 1. Verificați toate părțile componente înainte de instalare.
2. Înainte de a începe asamblarea, consultați capitolul. Măsuri de siguranță și protecție.

- BG** 1. Проверете всички части преди монтажа.
2. Преди започване на монтажа, моля разгледайте Безопасност и Защита.

- TR** 1. Kurulumdan önce tüm parçaları kontrol ediniz.
2. Montaja başlamadan önce lütfen Güvenlik ve Önlemler kısmına bakınız.



	VRC01	2
	VRC02	4
	VRC03	4
	VRC05	2
	VRC04	1
	VRC06	1
	VRC07	2
	VRC08	2
	VRC09	2
	VRC10	4
	VCLJ1	2
	VCLJ2	2
	WPJ1↑	2
	WPJ3↑	1
	WPJ2↑	2
	WPJ4↑	1
	WPJ5↓	1
	WPJ6↑	1
	WPJ7↓	1
	WPJ8↑	1
	RPC1	2
	RPC2	1
	BPJ3	1
	BPJ4	1

	FPC	2
	CLJ1	1
	CLK2	4
	CLJ4	1
	DLJ	1
	DRJ	1

	FDCL	1
	FDCR	1
	FCC	4
	VRJ09	4
	RJ	4
	BPS	16
	PPG	40
	PIN	40
	LH↑	2
	RH↑	2
	L	1
	R	1
	EC2	2
	S1	102
	S2	10
	S7	8
	SGC1	20
	SAC1	20
	S5	16
	S6	6
	PW	20
	SJ1	10
	BP	39
	WPC	4
	FP	4
	F1	6



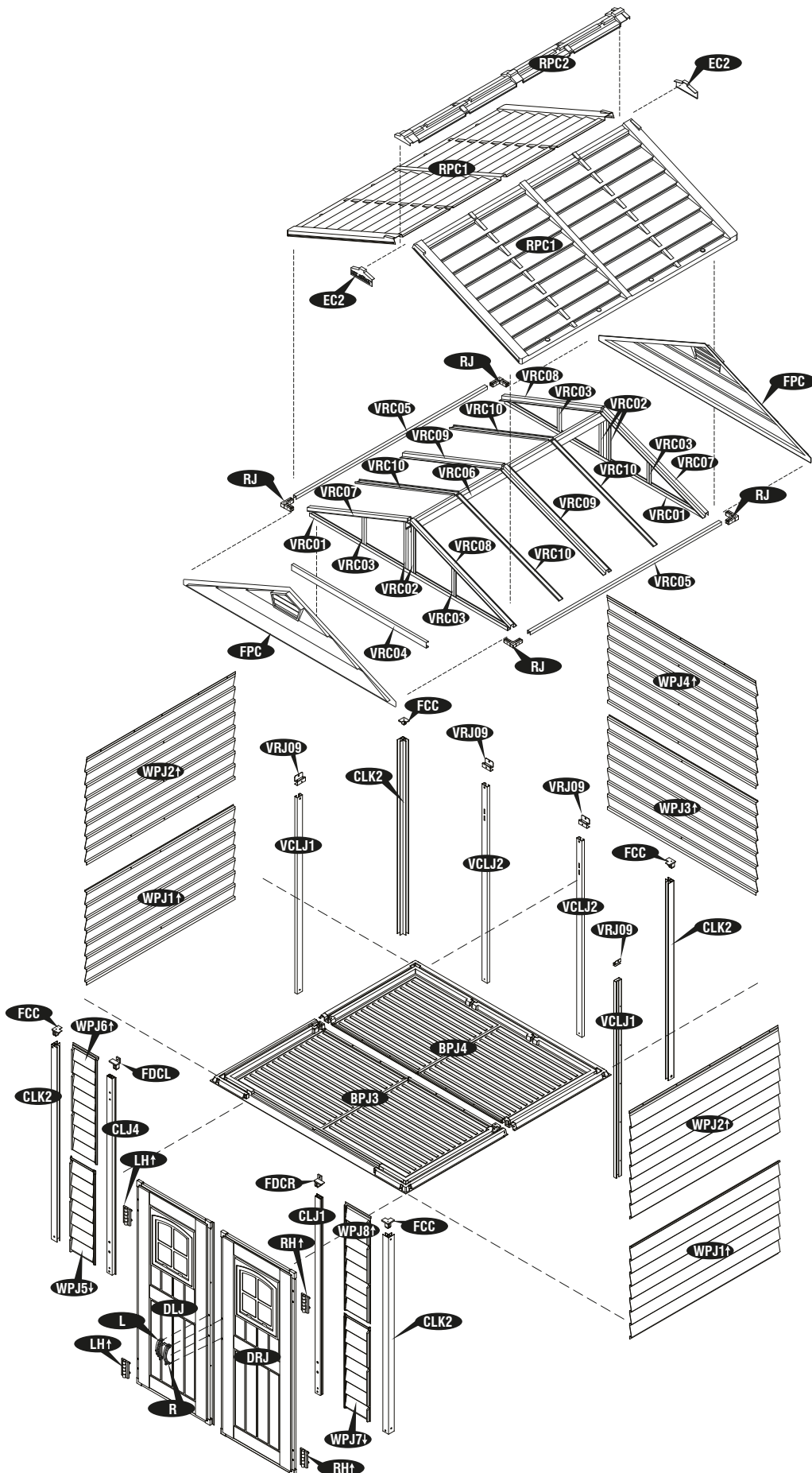

- 1 → # 14-15
- 2 → # 16-29
- 3 → # 30-40
- 4 → # 41-48
- 5 → # 49-54
- 6 → # 55-57

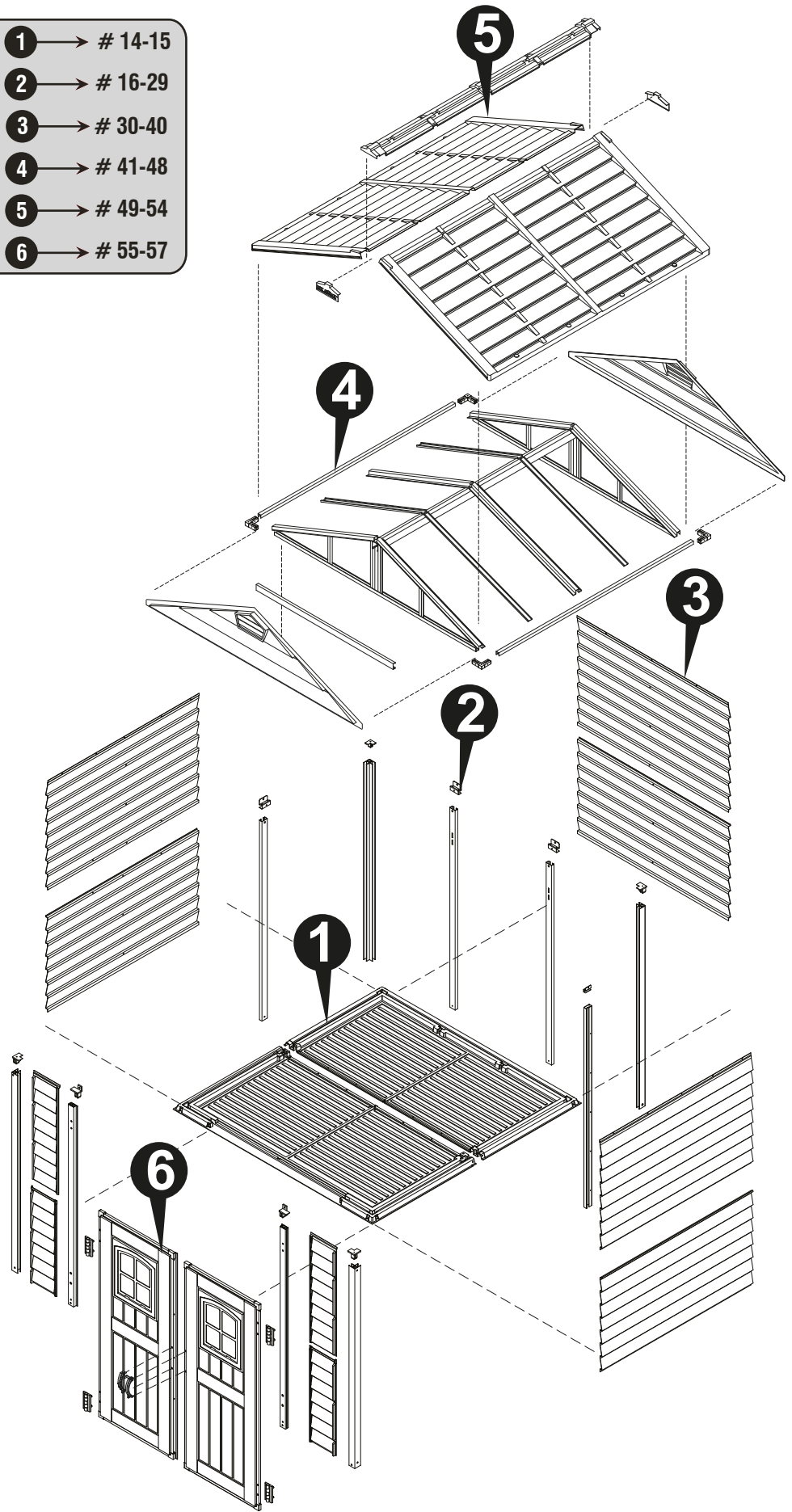

- EN** 1. Set the Torque limit of your Screw drill to #1 or #4 to ensure the Screws do not strip the Metal reinforcements.
2. It is important that these instructions are followed step by step.
3. Don't install under windy conditions.
4. All parts are clearly marked and care should be taken to use the correct one.
5. If you are building the shed against a wall, build it 2.5 ft. away then slide it in. (Only for Duramax foundation & Wooden foundation)

- FR** 1. Réglez la limite de couple de votre perceuse à vis sur # 1 ou # 4 pour assurer que les vis n'abîment pas les renforts métalliques.
2. Il est important que ces instructions soient suivies pas à pas.
3. Ne pas installer dans des conditions venteuses.
4. Toutes les pièces doivent être clairement identifiées, chaque pièce est spécifique à un endroit, ne pas l'utiliser si ce n'est pas clairement identifié dans le manuel d'instruction ci-dessous.
5. Si vous construisez l'abri contre un mur, construisez-le à un écart de 0,7 mètre, puis le glisser (seulement pour la fondation DuraMax et la fondation en bois).

- DE** 1. Stellen Sie das Drehmoment Ihres Akkuschaubers auf Stufe #1 oder #4. Dies verhindert ein Überdrehen der Schrauben.
2. Diese Anleitung muss unbedingt Schritt für Schritt befolgt werden.
3. Die Montage nicht bei windigem Wetter vornehmen.
4. Alle Teile sind deutlich gekennzeichnet und es ist darauf zu achten, dass die richtige verwendet wird.
5. Wenn Sie den Schuppen an einer Wand bauen, bauen sie es 2,5 Fuß weg, dann schieben Sie es ein.
(Nur für Duramax Fundament & Holzfundament)

- ES** 1. Establecer el límite de par de su taladro tornillo de #1 y #4 para que no traspasa los refuerzos metálicos
2. Es importante que estas instrucciones se sigan paso a paso.
3. No instale en días de mucho viento.
4. Recuerde que todas las piezas están marcadas para su correcto montaje.
5. Si usted está construyendo la caseta contra una pared, móntela a una distancia 2.5 pies (75cm) y una vez montada deslícela hacia la pared. (esto sólo es aplicable para la estructura de kit de suelo Duramax).

- PT** 1. Defina o limite de Torque de sua broca parafuso para #1 ou #4 para garantir que os parafusos não tira os reforços de metal.
2. É importante que estas instruções sejam seguidas passo a passo.
3. Não instale sob condições com forças ventanosas.
4. Todas as peças estão claramente marcadas e deve-se tomar cuidado para usar a correta.
5. Se você está construindo o galpão contra uma parede, construa-o a 2,5 pés de distância para então encostá-lo na mesma. (Apenas para o Duramax fundação e base de madeira)

- NL** 1. Stel de Torque limiet van uw Schroef boormachine op #1 en #4 om de schroeven zorgen niet strip de Metal versterkingen.
2. Het is belangrijk dat volgende instructies stap voor stap worden gerespecteerd.
3. Nooit de schuur installeren onder windige omstandigheden.
4. Alle onderdelen zijn duidelijk gemarkeerd en er moet op worden gelet dat de juiste wordt gebruikt.
5. Als u het schuur tegen muur aan het bouwen bent, bouwt u maar de schuur op 70cm afstand en schuif die er tegen de muur aan. (Alleen voor Duramax foundation & Houten foundation)

- CS** 1. Nastavte mezní hodnotu točivého momentu vrtacího vrtáku na #1 nebo #4, abyste zajistili, že šrouby neztáhnou kovové výztuhy.
2. Je důležité aby jste tento návod sledovali krok za krokem.
3. Nemontujte při větrném počasí.
4. Všechny díly jsou jasně označeny a je třeba dbát na správnou funkci.
5. Pokud stavíte přístřešek proti zdi, postavte jí 70cm stranou a poté jí přisuňte. (Pouze pro Duramax založení a dřevěné základy)

- SK** 1. Nastavte limit krútiaceho momentu vŕtacieho vŕtáka na #1 alebo #4, aby ste zaistili, že skrutky nezaberajú kovové výstuhy.
2. Je nutné dodržiavať tieto inštrukcie krok za krokom.
3. Neinštalujte za veterných podmienok.
4. Všetky časti sú zreteľne označené a treba dbať na to, aby boli použité správne.
5. Ak budujete múru, postavte ju 2,5 stôp. preč, a potom ju zasunúť. (Len pre Duramax založenie a drevené základy)



- SL** 1.Za omejitev vrtilnega momenta vijáčnega vijaka nastavite #1 ali #4, da zagotovite, da vijaki ne ojačijo kovinskih ojačitev.
2.Pomembno je, da sledite opisanim navodilom korak za korakom.
3.Montaže ne izvijajte, kadar piha močen veter.
4.Vsi deli so jasno označeni in pazite na pravilno uporabo.
5.Če se gradi skladišče proti steni, ga graditi 2,5 ft. stran, nato pa ga potisnite v. (samo za Duramax temelj in leseno osnovo)

- HR** 1.Postavite granico zakretnog momenta Vašeg vijčanog bušilica na #1 ili #4 kako biste osigurali da vijci ne skidaju metalna pojačanja.
2.To je važno da ovih instrukcije su slijedili korak po korak.
3.Nemojte instalirati pod vjetrovitim uvjetima.
4.Svi dijelovi su jasno označeni i treba voditi brigu o ispravnom korištenju.
5.Ako gradite proliveno zid, izgradite ga 2,5 m. daleko, a zatim ga gurnite. (Samo za Duramax zaklade i drveni temelja)

- HU** 1.Állítsa a csavarhúzó nyomatékhatárait #1 vagy #4-re, hogy a csavarok ne csavarják le a fém vasalatokat
2.Fontos, hogy az itt következő instrukciókat lépésről lépésre betartsa.
3.Szeles időben ne végezzen összeszerelést.
4.Minden alkatrész egyértelműen megjelölve, és gondoskodni kell a helyes használatáról.
5.Ha egy fészket építesz a falhoz, építsd meg 2,5 métert. távolítsa el, majd csúsztassa be. (Csak a Duramax Alapítvány és a Fa Alapítvány)

- SV** 1.Ställ in momentskruvren på din skruvborr till #1 eller #4 för att säkerställa att skruvarna inte slår av metallförstärkningarna.
2.Det är viktigt att dessa instruktioner följs steg för steg.
3.Installera inte när det är blåsigt.
4.Alla delar är tydligt märkta och försiktighet bör vidtas för att använda rätt.
5.Om du bygger ett skjul mot en vägg, bygg det 2,5 ft. bort och skjut in den. (Endast för Duramax Foundation & Wooden stiftelse)

- IT** 1. Impostare il limite di coppia della fresa a vite a #1 o #4 per assicurare che le viti non striscia i rinforzi metallici
2.E' molto importante che queste istruzioni vengano seguite passo dopo passo.
3.Non installare in presenza di forte vento.
4.Tutte le parti sono chiaramente contrassegnate e occorre prestare attenzione per utilizzare quella corretta.
5.Se si sta costruendo il capannone contro un muro, costruirlo 2,5 ft. via, poi farlo scorrere in. (Solo per Duramax Foundation e Fondazione di legno)

- PL** 1.Ustaw moc wkrętarki na #3 lub #4, aby upewnić się, że wkręty nie uszkodzą metalowych wzmocnień.
2.Bardzo ważne jest, by dokładnie stosować się do niniejszej instrukcji.
3.Nie należy montować w przypadku silnego wiatru.
4.Wszystkie części są wyraźnie oznaczone i należy zachować ostrożność, aby użyć właściwego.
5.Jeśli budujesz szopę przy ścianie, zbuduj ją 0,8 m dalej, a następnie wsuń. (Tylko dla fundamentów Duramax i fundamentów drewnianych)

- RO** 1.Setați limita de cuplu a burghiului dvs. de șurub la #1 sau #4 pentru a vă asigura că șuruburile nu lărgesc armăturile metalice.
2.Este importantă respectarea pas cu pas a acestor instrucțiuni.
3.Nu instalați dacă vântul atinge viteze mari.
4.Toate părțile sunt marcate în mod clar și trebuie să se țină seama de utilizarea celei corecte.
5.Dacă construiți vaporeșul pe perete, construiți-l la o distanță de 2,5 ft, apoi glisați-l. (Doar pentru fundația Duramax & fundație din lemn)

- BG** 1.Нагласете границата на въртящия момент на винтовата витла до #1 или #4, за да се уверите, че винтовете не изрязват металните подсилвания.
2.Важно е да следвате инструкциите стъпка по стъпка.
3.Да не се монтира при ветровито време.
4.Всички части са ясно маркирани и трябва да се внимава да се използва правилната.
5.Ако сте изградане на навес срещу стена, изградане то на 2,5 фута далеч след това го плъзнете инча (Само за Duramax фондация & дървени основи)

- TR** 1.Vidaların Metal takviyeleri soymadığından emin olmak için Vidalı matkabınızın Moment sınırını #1 veya #4'e ayarlayın.
2.Talimatların sırasıyla uygulanması önemlidir.
3.Rüzgarlı havalarda kurmayınız.
4.Tüm parçalar açıkça işaretlenmiştir ve doğru olanı kullanmak için özen gösterilmelidir.
5.Bir duvara kulübe bina varsa, o 2.5 ft kurmak. uzakta bir biçimde kaydırın. (Yalnızca Duramax vakif ve Ahşap vakif için)



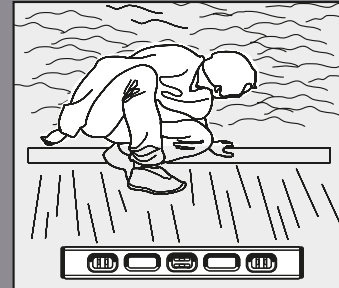

EN DuraMax sheds are best installed on a raised level ground or a concrete foundation. If the shed is installed at ground level, ensure that there is proper water drainage sloping away from the shed so rain water does not pool and get inside the shed. For heavy rain areas, place the shed on a raised foundation which will have minimum outside dimensions of 86 7/8" x 86 7/8" (2206mm x 2206mm).

FR Les remises DuraMax sont mieux installées sur un sol surélevé ou sur une fondation en béton. Si le abri est installé au niveau du sol, assurez-vous qu'il y a un drainage adéquat de l'eau en pente loin du hangar pour que l'eau de pluie ne s'accumule pas et ne pénètre pas dans le hangar. Pour les zone de fortes précipitations, placez la remise sur une fondation surélevée qui aura des dimensions extérieures minimales de 86 7/8" x 86 7/8" (2206mm x 2206mm).

DE DuraMax-Schuppen werden am besten auf einem erhöhten Boden oder einem Betonfundament installiert. Wenn der Schuppen in Bodennähe installiert ist, stellen Sie sicher, dass eine ordnungsgemäße Wasserableitung vom Schuppen abfällt, damit sich kein Regenwasser ansammelt und in den Schuppen gelangt. Stellen Sie den Schuppen bei starkem Regen auf ein erhöhtes Fundament mit minimalen Außenabmessungen von 86 7/8" x 86 7/8" (2206mm x 2206mm)).

ES Los cobertizos DuraMax se instalan mejor en un terreno nivelado o en una base de concreto. Si el cobertizo se instala a nivel del suelo, asegúrese de que haya un drenaje de agua adecuado en una pendiente que se aleje del cobertizo para que el agua de lluvia no se acumule y entre en el cobertizo. Para áreas de lluvia intensa, coloque el cobertizo sobre una base elevada que tendrá unas dimensiones exteriores mínimas de 86 7/8" x 86 7/8" (2206mm x 2206mm).

PT Os galpões DuraMax são mais bem instalados em um terreno elevado ou em uma fundação de concreto. Se o galpão for instalado no nível do solo, certifique-se de que haja drenagem de água adequada inclinando-se para longe do galpão para que a água da chuva não se acumule e entre no galpão. Para áreas de chuva forte, coloque o galpão em uma fundação elevada que terá dimensões externas mínimas de 86 7/8" x 86 7/8" (2206mm x 2206mm).

NL DuraMax-loosden kunnen het beste worden geïnstalleerd op een verhoogde, vlakke ondergrond of op een betonnen fundering. Als de schuur op de begane grond wordt geïnstalleerd, zorg er dan voor dat er een goede waterafvoer is die wegloopt van de schuur, zodat regenwater niet in de schuur terecht komt. Plaats bij zware regenval de schuur op een verhoogde fundering met een minimale buitenafmeting van 86 7/8" x 86 7/8" (2206mm x 2206mm).

CS Přístřešky DuraMax se nejlépe instalují na vyvýšený rovný podklad nebo na betonový základ. Pokud je bouda instalována na úrovni terénu, zajistěte, aby z ní byl dostatečný odtok vody, aby se srážková voda nehromadila a nedostala se do boudy. V oblastech se silným deštěm umístěte boudu na vyvýšený základ, který bude mít minimální vnější rozměry 86 7/8" x 86 7/8" (2206mm x 2206mm).

SK Búdy DuraMax sa najlepšie inštalujú na vyvýšený rovný podklad alebo na betónový základ. Ak je búda inštalovaná na úrovni terénu, zabezpečte dostatočný odtok vody od boudy, aby sa dažďová voda nehromadila a nedostala sa do boudy. V prípade silných dažďových plôch umiestnite boudu na vyvýšený základ, ktorý bude mať minimálne vonkajšie rozmery 86 7/8" x 86 7/8" (2206mm x 2206mm).

SL DuraMax lope je najbolje namestiti na povišani tleh ali betonski podlagi. Če je lopa nameščena na tleh, poskrbite, da bo odtok vode pravilno nagnjen stran od lope, da se deževnica ne bo združila in vstopila v lopo. Za območja z močnim dežjem postavite lopo na dvignjen temelj, ki bo imel najmanjše zunanje mere 86 7/8" x 86 7/8" (2206mm x 2206mm).

HR DuraMax šupe najbolje je instalirati na povišenom tlu ili betonskom temelju. Ako je šupa postavljena u razini tla, pobrinite se da postoji odgovarajuća odvodnja vode koja se kosi od šupe kako se kišnica ne bi udružila i ušla u šupu. Za područja s jakim kišom, postavite šupu na povišeni temelj koji će imati minimalne vanjske dimenzije od 86 7/8" x 86 7/8" (2206mm x 2206mm).



HU A DuraMax fészereket a legjobban egy magasra emelt talajra vagy egy beton alapra lehet felszerelni. Ha a fészert talajszinten van felszerelve, győződjön meg arról, hogy megfelelő vízvezetés van-e lejtve az istállótól, hogy az esővíz ne gyűljön össze és ne kerüljön a fészerbe. Heves esőzések esetén helyezze az istállót egy megemelt alapra, amelynek legkisebb külső méretei 86 7/8" x 86 7/8" (2206mm x 2206mm).

SV DuraMax-skjulet installeras bäst på en upplyft mark eller en betongfundament. Om skjulet installeras på marknivå, se till att det finns korrekt vattendränning lutande bort från skjulet så att regnvatten inte slår sig samman och kommer in i skjulet. För kraftiga regnområden, placera skjulet på ett upphöjt underlag som har minsta utvändiga dimensioner på 86 7/8" x 86 7/8" (2206mm x 2206mm).

IT I capannoni DuraMax si installano al meglio su un terreno rialzato o su una fondazione in calcestruzzo. Se il capannone è installato a livello del suolo, assicurarsi che vi sia un adeguato drenaggio dell'acqua in pendenza dal capannone in modo che l'acqua piovana non si accumuli e penetri all'interno del capannone. Per le aree con forti piogge, posizionare il capannone su una fondazione rialzata che avrà dimensioni esterne minime di 86 7/8" x 86 7/8" (2206mm x 2206mm).

PL Szopy DuraMax najlepiej instalować na podwyższonym poziomym gruncie lub na betonowym fundamencie. Jeśli szopa jest zainstalowana na poziomie gruntu, upewnij się, że jest odpowiedni odpływ wody, który spływa z dala od szopy, aby woda deszczowa nie gromadziła się i nie dostawała się do szopy. W przypadku intensywnych opadów deszczu należy umieścić szopę na podwyższonym fundamencie o minimalnych wymiarach zewnętrznych 86 7/8" x 86 7/8" (2206mm x 2206mm).

RO Depozitele DuraMax se instalează cel mai bine pe un teren înălțat sau pe o fundație din beton. Dacă magazia este instalată la nivelul solului, asigurați-vă că există o scurgere adecvată a apei înclinată de la magazie, astfel încât apa de ploaie să nu se strângă și să pătrundă în interiorul magaziei. Pentru zonele cu ploi abundente, așezați magazia pe o fundație ridicată, care va avea dimensiuni exterioare minime de 86 7/8" x 86 7/8" (2206mm x 2206mm).

BG Бараките DuraMax се инсталират най-добре на повдигнато ниво или върху бетонна основа. Ако навесът е монтиран на нивото на земята, уверете се, че има подходящ дренаж за вода, наклонен от навеса, така че дъждовната вода да не се обединява и да влиза вътре в навеса. За места с обилен дъжд поставете навеса върху повдигната основа, която ще има минимални външни размери от 86 7/8" x 86 7/8" (2206mm x 2206mm).

TR DuraMax hangarlar en iyi şekilde yükseltilmiş bir zemine veya beton bir temel üzerine kurulur. Hangar zemin seviyesinde kuruluysa, yağmur suyunun havuza girip kulübenin içine girmemesi için kulübeden uzağa doğru eğimli uygun su tahliyesi olduğundan emin olun. Şiddetli yağmurlu alanlar için, kulübeyi minimum 86 7/8" x 86 7/8" (2206mm x 2206mm) dış boyutları olan yükseltilmiş bir temel üzerine yerleştirin.

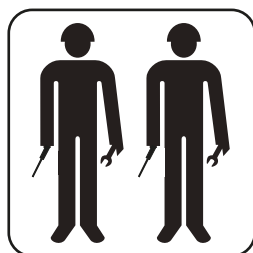

EN Two people needed.

FR Deux personnes nécessaires.

DE Zwei Leute brauchen.

ES Dos personas que se necesitan.

PT Duas pessoas precisavam.

NL Er waren twee mensen nodig.

CS Potřebovali dva lidi.

SK Dvaja ľudia potrebovali.

SL Potrebovali sta dve osebi.

HR Trebale su dvije osobe.

HU Két embernek volt szüksége.

SV Två personer behövde.

IT Sono necessarie due persone.

PL Potrzebne były dwie osoby.

RO Două persoane au avut nevoie.

BG Нужни бяха двама души.

TR İki kişiye ihtiyaç vardı.





1

- | | | |
|---------------------------|-------------------|-------------------------------|
| EN Floor Assembly | CS Montáž podlahy | IT Assemblaggio del pavimento |
| FR Assemblage de plancher | SK Montáž podlahy | |
| DE Bodenmontage | SL Montaža tal | PL Montaż podłogi |
| ES Montaje de suelo | HR Podna montaža | RO Asamblarea podelei |
| PT Conjunto de piso | HU Padlószerezés | BG Сглобяване на подае |
| NL Montage op de vloer | SV Golvmontering | TR Zemin Montajı |

- | | | |
|-----------------------|-----------------------------------|-----------------------------------|
| EN Parts needed | CS Potřebné součásti | IT Parti occorrenti |
| FR Pièces nécessaires | SK Potrebne časti | PL Niezbędne elementy |
| DE Benötigte Teile | SL Dele, ki jih boste potrebovali | RO Elementele componente necesare |
| ES Piezas necesitadas | HR Dijelovi potreban | BG Необходими части |
| PT Peças Necessárias | HU Szükséges részek | TR Gerekli parçalar |
| NL Onderdelen nodig | SV Delar som behövs | |

BPJ3	1
BPJ4	1
BP	11



- EN** Apply silicone on all the floor joining overlapping area to avoid water penetrating inside. [Silicon not included].
Use Same color Plugs(BP).
- FR** Appliquez du silicone sur toute la zone de chevauchement joignant le sol pour éviter que l'eau ne pénètre à l'intérieur. [Silicium non inclus].
Utilisez les bouchons de même couleur (BP).
- DE** Tragen Sie Silikon auf den gesamten Boden auf und verbinden Sie den überlappenden Bereich, um zu verhindern, dass Wasser in das Innere eindringt. [Silizium nicht enthalten].
Verwenden Sie die gleichen Farbstoffen (BP).
- ES** Aplique silicona en todo el piso que une el área de superposición para evitar que el agua penetre en el interior. [Silicona no incluida].
Utilice tapones del mismo color (BP).
- PT** Aplique silicone em toda a área de sobreposição da junta do piso para evitar a entrada de água. [Silício não incluído].
Use os plugues da mesma cor (BP).
- NL** Breng siliconen aan op alle overlappende delen van de vloer om te voorkomen dat er water binnendringt. [Silicium niet inbegrepen].
Gebruik pluggen in dezelfde kleur (BP).
- CS** Naneste silikon na celou podlahu spojující překrývající se oblast, aby nedocházelo k pronikání vody dovnitř. [Silikon není zahrnut].
Použijte zástrčky stejné barvy (BP).
- SK** Naneste silikón na celú podlahu spájajúcu prekrývajúcu sa oblasť, aby ste zabránili prenikaniu vody dovnútra. [Kremík nie je súčasťou balenia].
Použite zástrčky rovnakej farby (BP).
- SL** Nanesite silikon na vsa tla, ki se prekrivajo, da preprečite prodiranje vode v notranjost. [Silicij ni vključen].
Uporabite iste barvne vtiče (BP).
- HR** Nanesite silikon na cijeli pod koji spaja preklapajuće područje kako biste izbjegli prodor vode unutra. [Silicij nije uključen].
Upotrijebite utikače iste boje (BP).
- HU** Vigyen fel szilikont a padló összes csatlakozó felületére, hogy elkerülje a víz behatolását. [A szilíciumot nem tartalmazza].
Használjon azonos színű dugókat (BP).
- SV** Applicera silikon på hela golvetns överlappande område för att undvika att vatten tränger in i det. [Kisel ingår ej].
Använd samma färgpluggar (BP).
- IT** Applicare il silicone su tutta l'area di sovrapposizione del pavimento per evitare che l'acqua penetri all'interno. [Silicio non incluso].
Utilizzare spine dello stesso colore (BP).
- PL** Nałóżć silikon na wszystkie zachodzące na siebie połączenia podłogi, aby woda nie dostała się do środka. [Nie zawiera krzemiu].
Użyj wtyczek tego samego koloru (BP).
- RO** Aplicați silicon pe toată podeaua, unind zona suprapusă, pentru a evita pătrunderea apei în interior. [Siliciul nu este inclus].
Folosiți fișe de aceeași culoare (BP).
- BG** Нанесете силикон върху целия под, свързващ припокриващата се зона, за да избегнете проникването на вода вътре. [Силиций не е включен].
Използвайте едни и същи цветни щепсели (BP).
- TR** İçeriye su girmesini önlemek için tüm zemin birleşim yerlerinin üst üste binen alanına silikon uygulayın. [Silikon dahil değildir].
Aynı renkteki Fişleri (BP) kullanın.

1

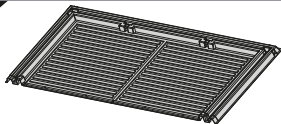

BPJ4 (x1)

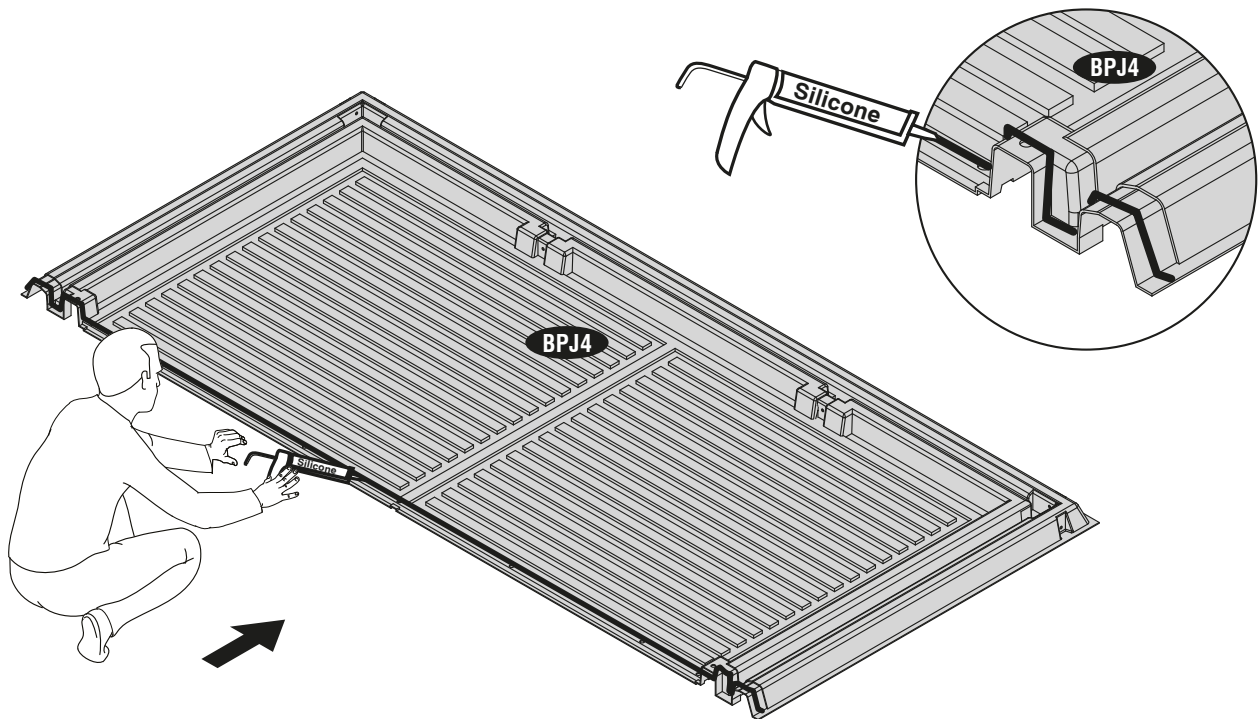
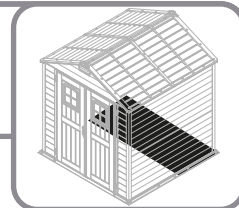

2

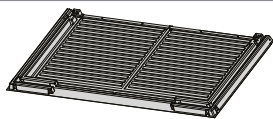

BPJ3 (x1)

BP (x11)

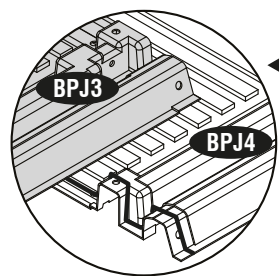
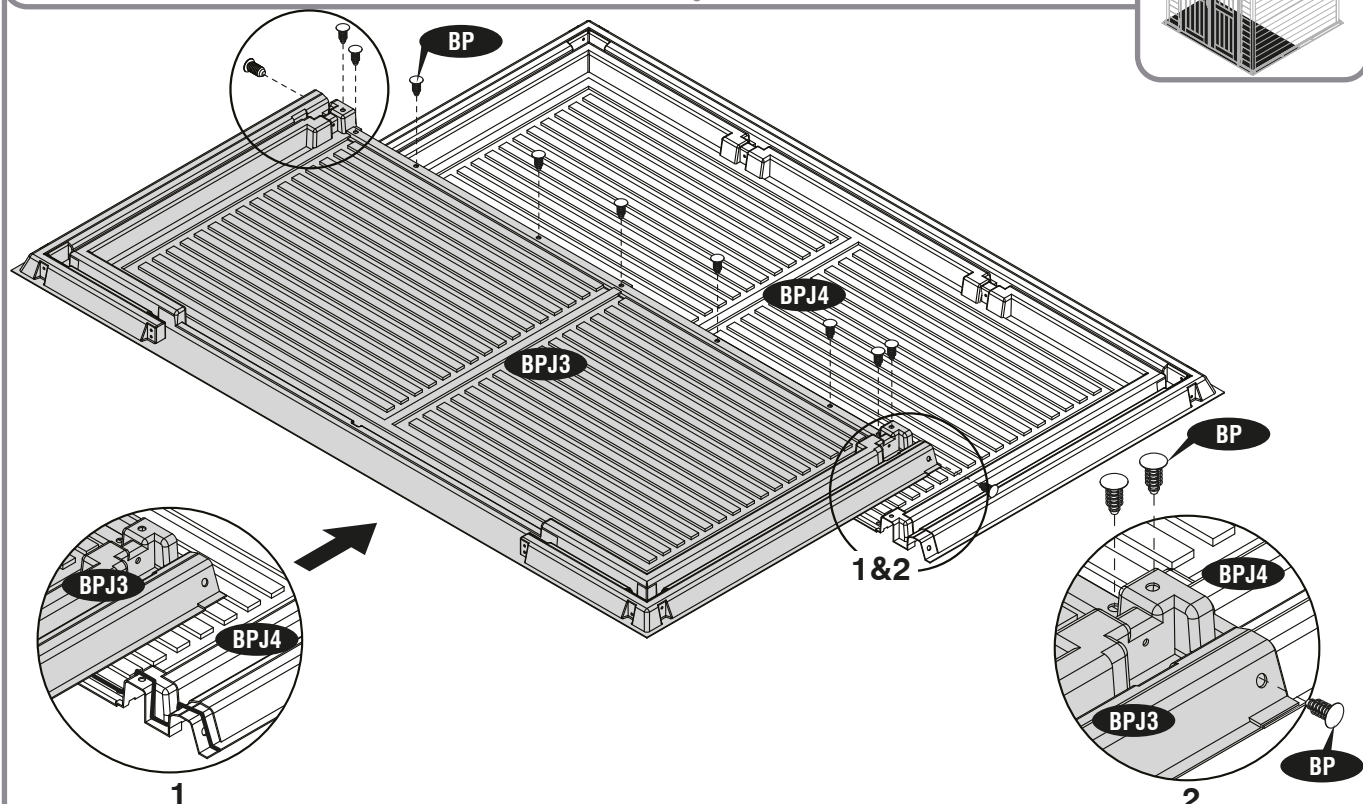
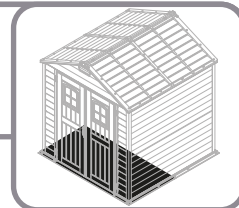

1

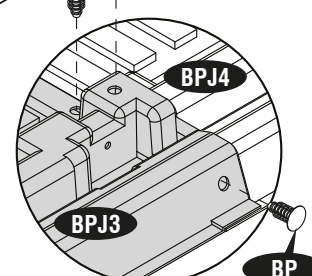

2



2

EN Pre Assembly	CS Předmontáž	IT Pre assemblato
FR Pré-assemblage	SK Pred zhromaždením	PL Przed montażem
DE Vormontage	SL Pred montažo	RO Pre asamblat
ES Preasamblea	HR Pred montaža	BG Предварително събрание
PT Pré Assembléia	HU Előgyűlés	TR Ön montaj
NL Voorgemonteerd	SV Färdigmonterad	

EN Parts needed	CS Potřebné součásti	IT Parti occorrenti
FR Pièces nécessaires	SK Potřebné časti	PL Niezbędne elementy
DE Benötigte Teile	SL Dele, ki jih boste potrebovali	RO Elementele componente necesare
ES Piezas necesarias	HR Dijelovi potreban	BG Необходими части
PT Peças Necessárias	HU Szükséges részek	TR Gerekli parçalar
NL Onderdelen nodig	SV Delar som behövs	

VCLJ1	2	WPJ3 ↑	1	RJ	4
VCLJ2	2	WPJ4 ↑	1	WPC	4
VRC01	2	WPJ5 ↓	1	SAC1	20
VRC02	4	WPJ6 ↑	1	S1	38
VRC03	4	WPJ7 ↓	1		
VRC04	1	WPJ8 ↑	1		
VRJ09	4	CLJ1	1		
WPJ1 ↑	2	CLK2	4		
WPJ2 ↑	2	CLJ4	1		



A

EN Side Wall Pre-Assembly	HR Predmontaža bočnog zida
FR Pré-assemblage de paroi latérale	HU Oldalsó fal előszerelése
DE Vormontage der Seitenwand	SV Förmontering av sidovägg
ES Premontaje de la pared lateral	IT Pre-assemblaggio parete laterale
PT Pré-montagem da parede lateral	PL Wstępny montaż ściany bocznej
NL Voormontage zijwand	RO Pre-asamblare perete lateral
CS Předběžná montáž boční stěny	BG Предварително сглобяване на страничната стена
SK Predbežná montáž bočnej steny	TR Yan Duvar Ön Montajı
SL Predmontaža stranske stene	

1

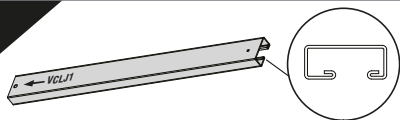

VCLJ1 (x2)



VRJ09 (x2)



S1 (x2)

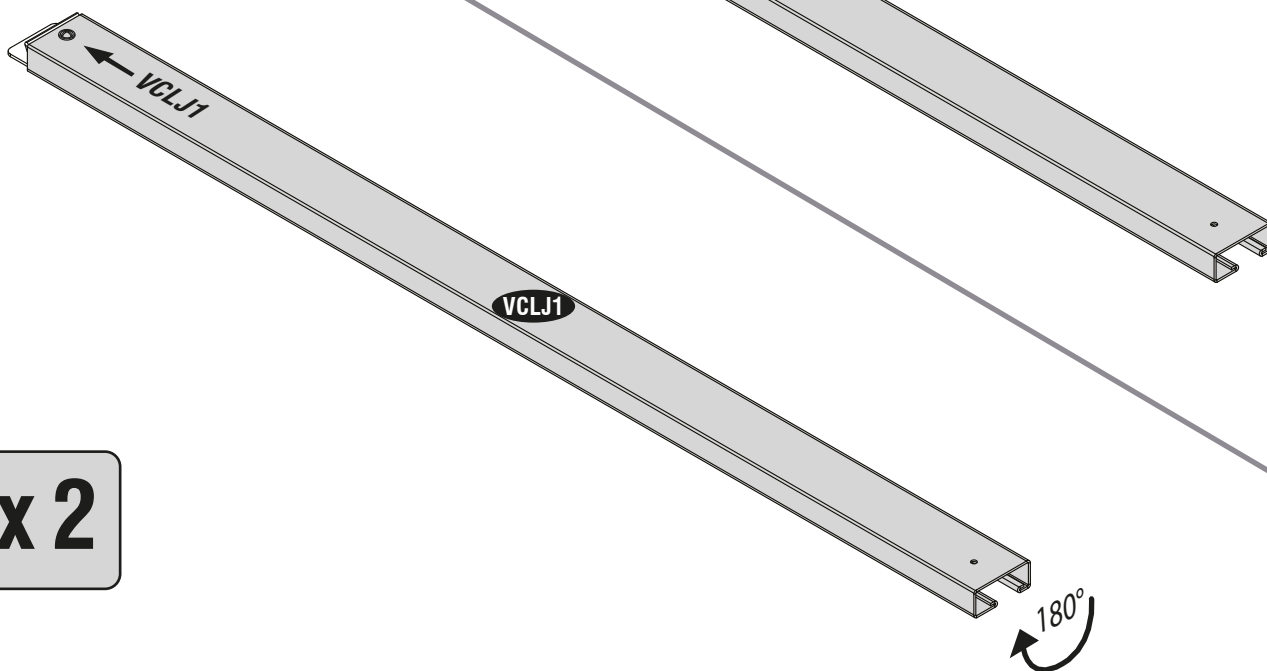
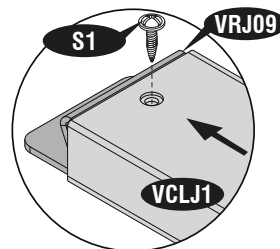
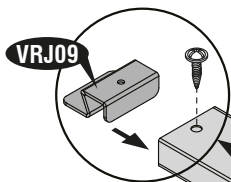

x2



EN After fix (VRJ09) turn the Column Assembly(VCLJ1) 180°.

FR Après la correction (VRJ09), tournez l'assemblage de colonne (VCLJ1) de 180°.

DE Nach dem Fixieren (VRJ09) drehen Sie die Säulenbaugruppe (VCLJ1) um 180°.

ES Después de la reparación (VRJ09), gire el conjunto de columna (VCLJ1) 180°.

PT Depois de corrigir (VRJ09), gire o conjunto da coluna (VCLJ1) 180°.

NL Na bevestiging (VRJ09) de kolomconstructie (VCLJ1) 180° draaien.

CS Po opravě (VRJ09) otočte sloupovou sestavu (VCLJ1) o 180°.

SK Po oprave (VRJ09) otočte stĺpový zostavu (VCLJ1) o 180°.

SL Po pritrditvi (VRJ09) obrnite sklop stolpca (VCLJ1) za 180°.

HR Nakon popravka (VRJ09) okrenite sklop stupca (VCLJ1) za 180°.

HU A rögzítés (VRJ09) után fordítsa el az oszlopszerelvényt (VCLJ1) 180°-kal.

SV Efter fix (VRJ09) vrider du kolumnenheten (VCLJ1) 180°.

IT Dopo la correzione (VRJ09) ruotare l'assieme colonna (VCLJ1) di 180°.

PL Po zamocowaniu (VRJ09) obróć zespół kolumny (VCLJ1) o 180°.

RO După remediere (VRJ09) rotiți ansamblul coloanei (VCLJ1) la 180°.

BG След фиксиране (VRJ09) завъртете колоната (VCLJ1) на 180°.

TR Sabitlemeden sonra (VRJ09) Kolon Tertibatını (VCLJ1) 180° döndürün.

2



WPJ1↑ (x2)



SAC1 (x4)

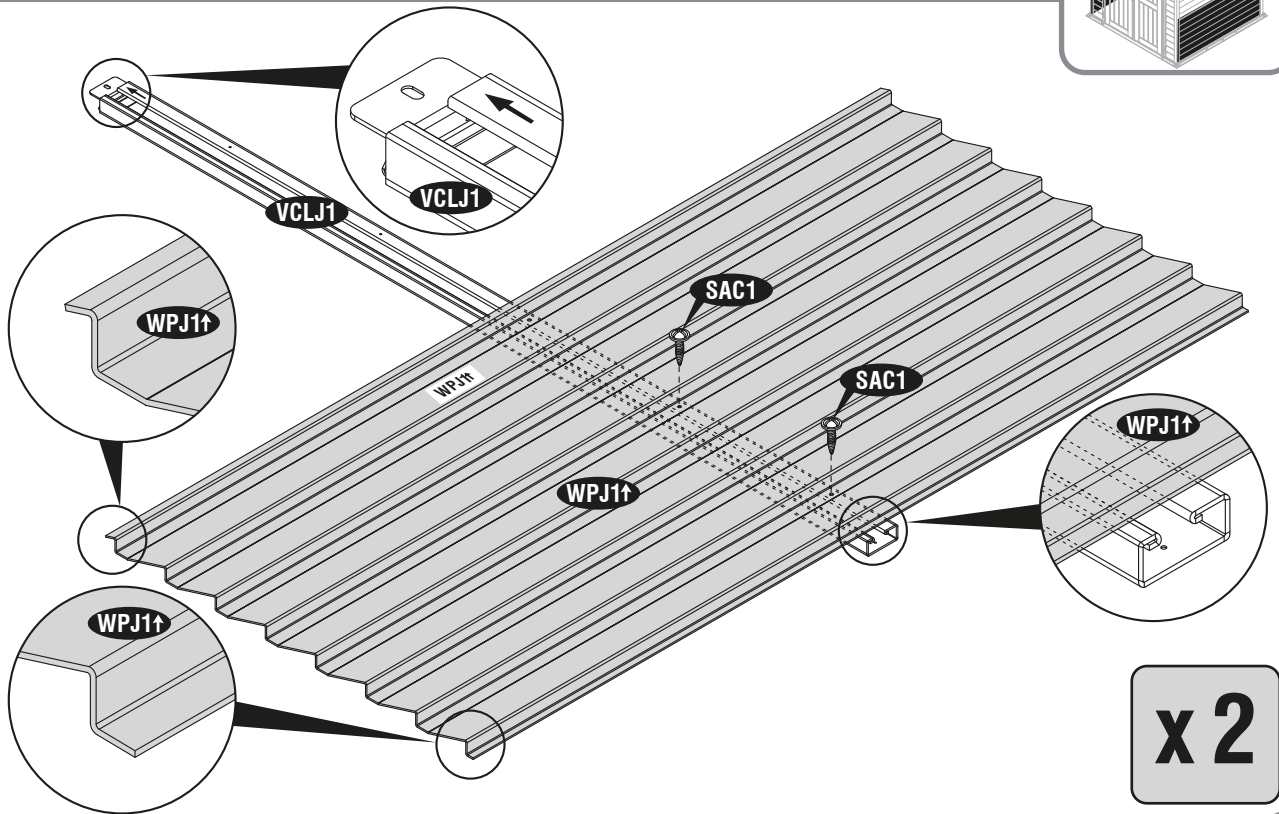

3

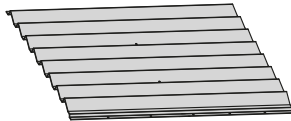

WPJ2↑ (x2)



SAC1 (x6)

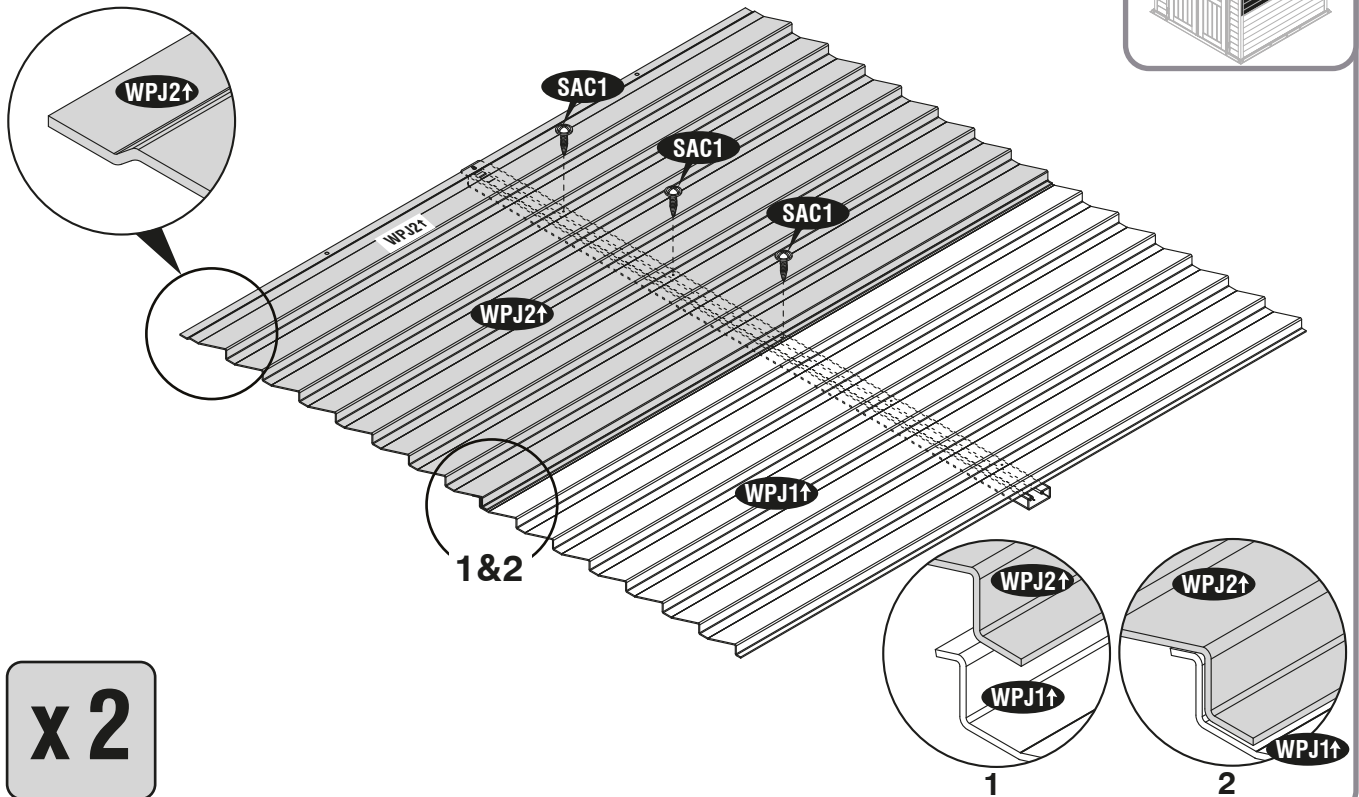
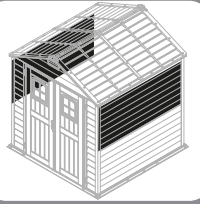



- EN After fix (WPJ2) turn the Wall Assembly 180°.
- FR Après la correction (WPJ2), tournez l'assemblage mural de 180°.
- DE Nach dem Fixieren (WPJ2) drehen Sie die Wandbaugruppe um 180°.
- ES Después de la reparación (WPJ2), gire el montaje de pared 180°.
- PT Após a correção (WPJ2), gire o conjunto de parede 180°.
- NL Na bevestiging (WPJ2) de wandmontage 180° draaien.
- CS Po opravě (WPJ2) otočte nástěnnou sestavu o 180°.
- SK Po upevnení (WPJ2) otočte stenovú zostavu o 180°.
- SL Po pritrditvi (WPJ2) obrnite stenski sklop za 180°.
- HR Nakon popravka (WPJ2) okrenite zidni sklop za 180°.
- HU Javítás (WPJ2) után fordítsa el a faligységet 180°-kal.
- SV Vrid väggmonteringen 180° efter fix (WPJ2).
- IT Dopo il fissaggio (WPJ2) ruotare l'assieme a parete di 180°.
- PL Po zamocowaniu (WPJ2) obróć zespół ścienny o 180°.
- RO După fixare (WPJ2) rotiți ansamblul de perete la 180°.
- BG След фиксиране (WPJ2) завъртете стенния монтаж на 180°.
- TR Sabitlemeden sonra (WPJ2) Duvar Tertibatını 180° döndürün.



4

 WPC (x4)



x2

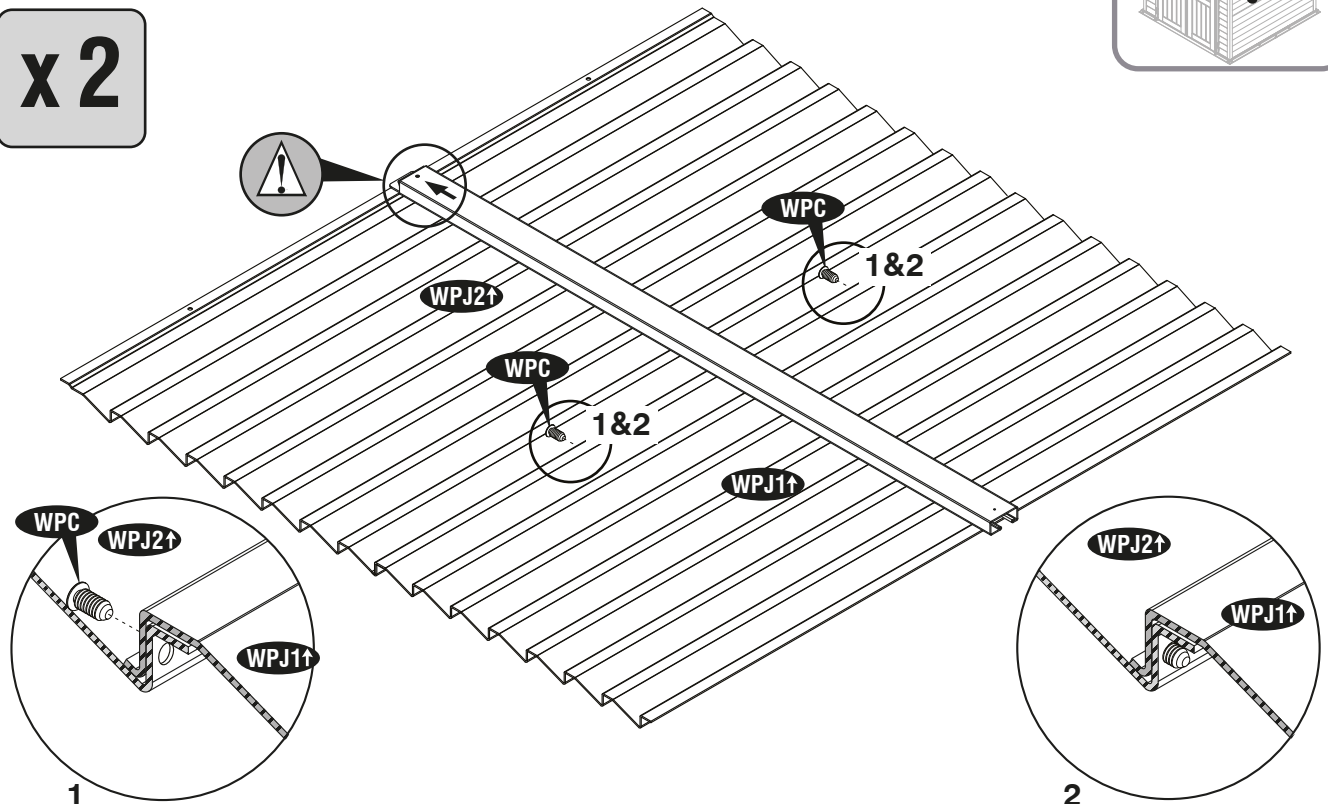

5

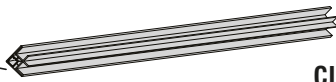

CLK2 ↑ (x4)



S1 (x12)

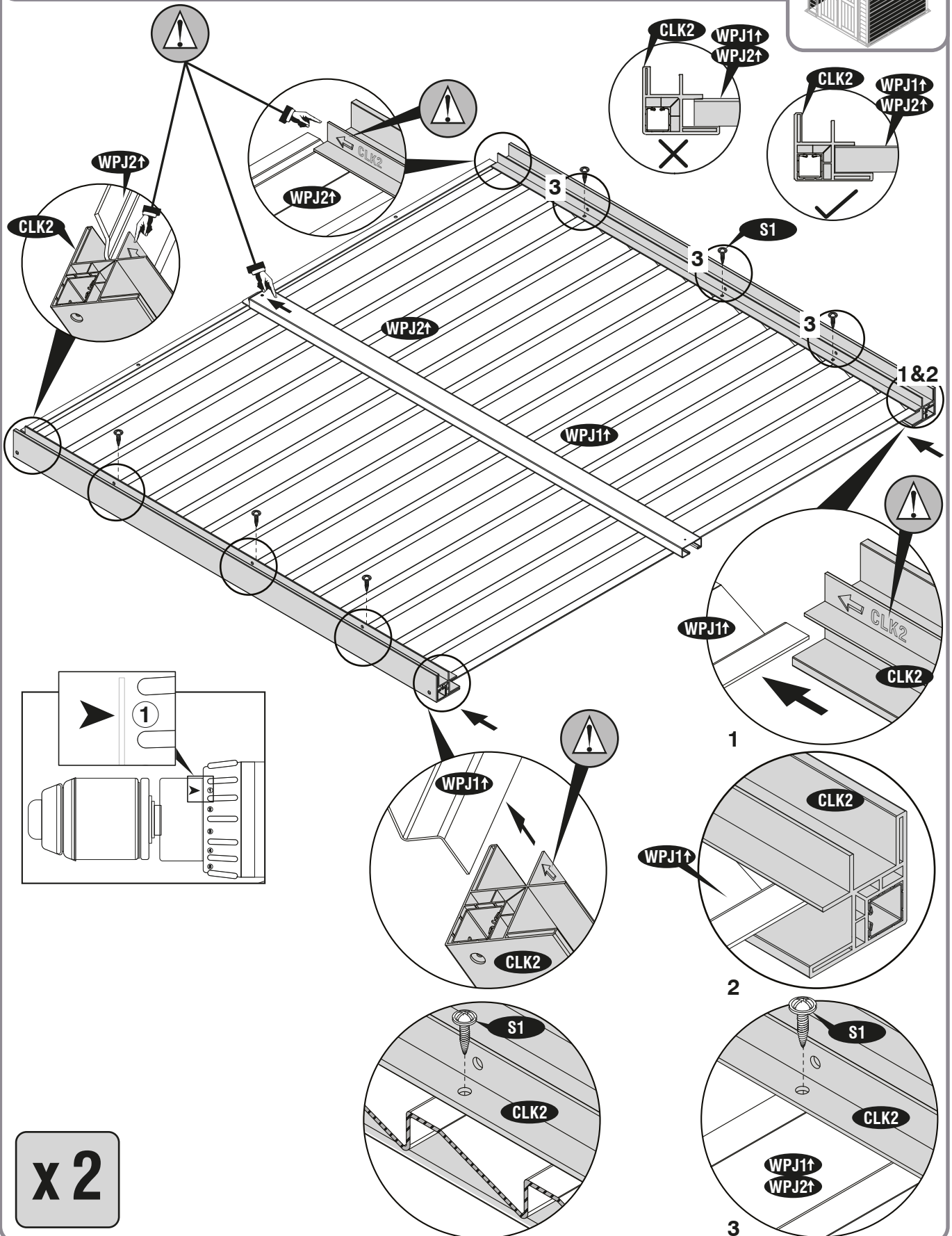

x 2

B

- | | |
|------------------------------------|--|
| EN Back Wall Pre-Assembly | HR Pred montaža stražnjeg zida |
| FR Pré-assemblage du mur arrière | HU Hátfal előszerelés |
| DE Vormontage der Rückwand | SV Förmontering av bakvägg |
| ES Premontaje de la pared trasera | IT Pre-assemblaggio parete posteriore |
| PT Pré-montagem da parede traseira | PL Wstępny montaż tylnej ściany |
| NL Voormontage achterwand | RO Pre-asamblarea peretelui din spate |
| CS Předmontáž zadní stěny | BG Предварително сглобяване на задната стена |
| SK Predbežná montáž zadnej steny | TR Arka Duvar Ön Montajı |
| SL Predmontaža zadnje stene | |

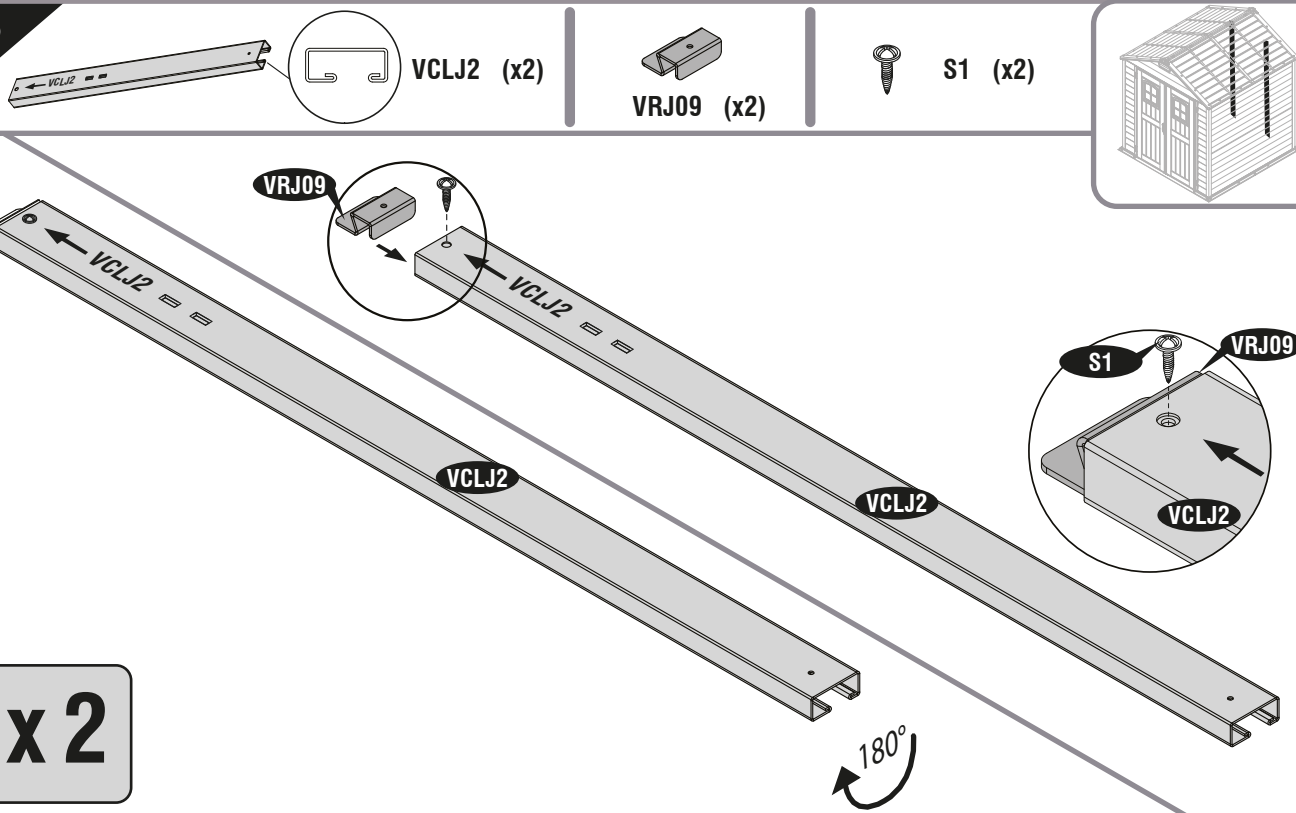
6**x2**

- | | |
|--|---|
| EN After fix (VRJ09) turn the Column Assembly(VCLJ2) 180°. | HR Nakon popravka (VRJ09) okrenite sklop stupca (VCLJ2) za 180°. |
| FR Après la correction (VRJ09), tournez l'assemblage de colonne (VCLJ2) de 180°. | HU A rögzítés (VRJ09) után fordítsa el az oszlopszerelvényt (VCLJ2) 180°-kal. |
| DE Nach dem Fixieren (VRJ09) drehen Sie die Säulenbaugruppe (VCLJ2) um 180°. | SV Efter fix (VRJ09) vrider du kolumnenheten (VCLJ2) 180°. |
| ES Después de la reparación (VRJ09), gire el conjunto de columna (VCLJ2) 180°. | IT Dopo la correzione (VRJ09) ruotare l'assieme colonna (VCLJ2) di 180°. |
| PT Depois de corrigir (VRJ09), gire o conjunto da coluna (VCLJ2) 180°. | PL Po zamocowaniu (VRJ09) obróć zespół kolumny (VCLJ2) o 180°. |
| NL Na bevestiging (VRJ09) de kolomconstructie (VCLJ2) 180° draaien. | RO După remediere (VRJ09) rotiți ansamblul coloanei (VCLJ2) la 180°. |
| CS Po opravě (VRJ09) otočte sloupovou sestavu (VCLJ2) o 180°. | BG След фиксиране (VRJ09) завъртете колоната (VCLJ2) на 180°. |
| SK Po oprave (VRJ09) otočte stĺpovú zostavu (VCLJ2) o 180°. | TR Sabitlemeden sonra (VRJ09) Kolon Tertibatını (VCLJ2) 180° döndürün. |
| SL Po pritrditvi (VRJ09) obrnite sklop stolpca (VCLJ2) za 180°. | |

7



WPJ3↑ (x1)



SAC1 (x4)

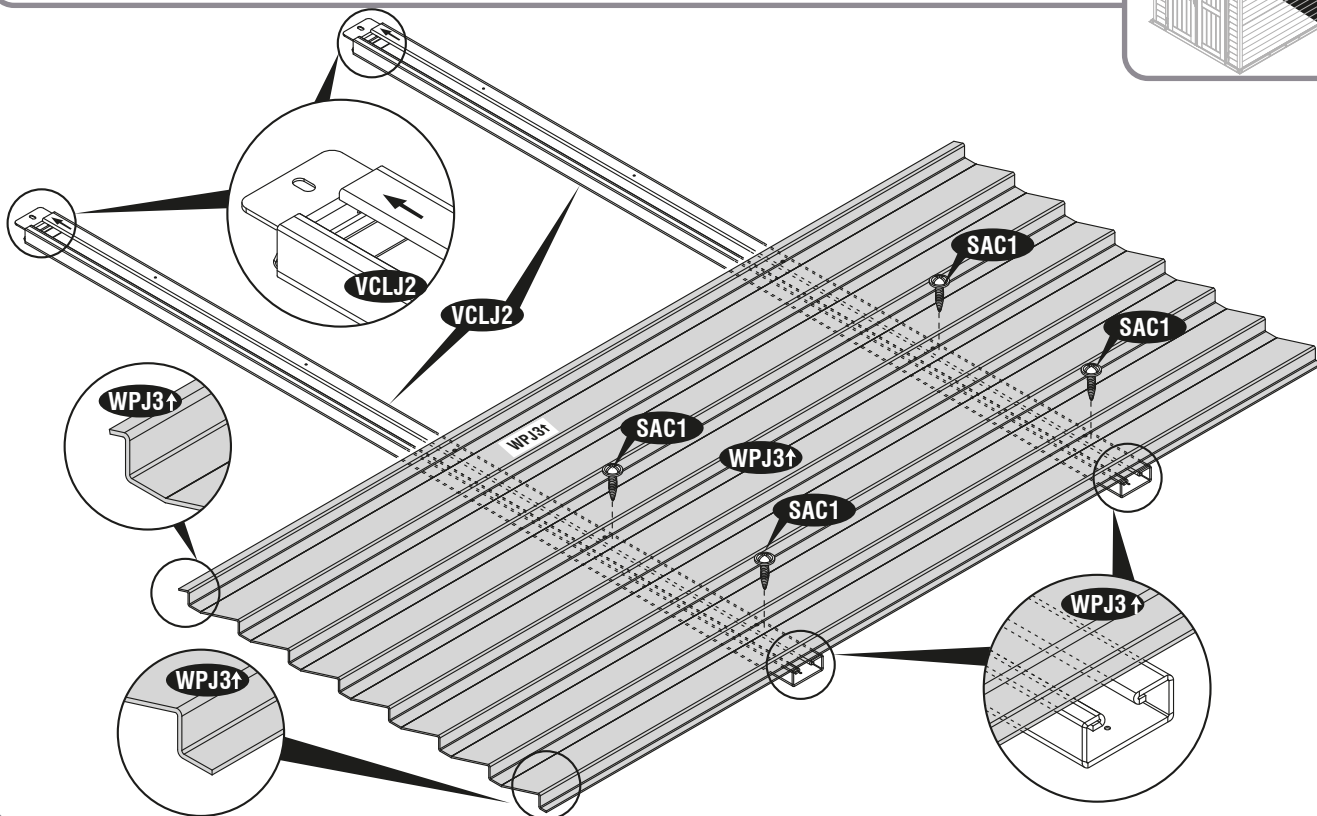
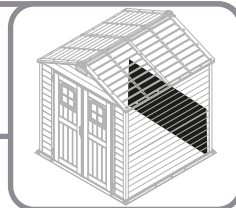

8



WPJ4↑ (x1)



SAC1 (x6)

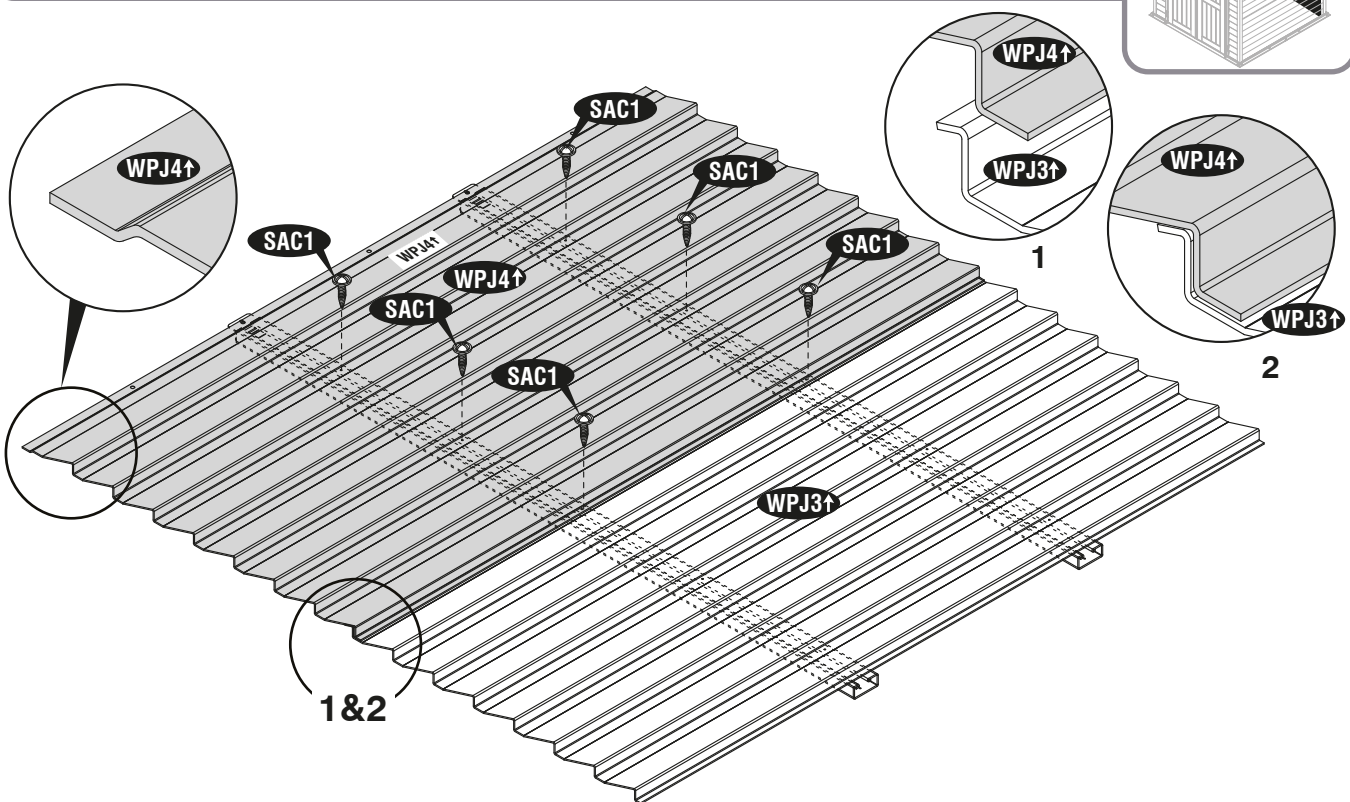
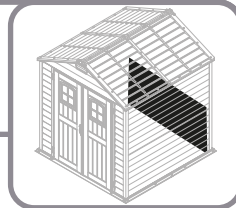

C

- EN Front Left Wall Pre-Assembly
- FR Pré-assemblage de la paroi avant gauche
- DE Vormontage der vorderen linken Wand
- ES Premontaje de la pared delantera izquierda
- PT Pré-montagem da parede frontal esquerda
- NL Voormontage linkermuur
- CS Předmontáž přední levé stěny
- SK Predná montáž na ľavú stenu
- SL Predsestavitev sprednje leve stene
- HR Pred montaža prednjeg lijevog zida
- HU A bal első fal előszerelése
- SV Frammontering av vänster vägg fram
- IT Pre-assemblaggio parete anteriore sinistra
- PL Wstępny montaż przedniej lewej ściany
- RO Pre-asamblare perete stânga față
- BG Пред-лява стена Предварително сглобяване
- TR Ön Sol Duvar Ön Montajı

9

WPJ5↓ (x1)

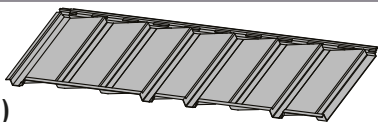

WPJ6↑ (x1)

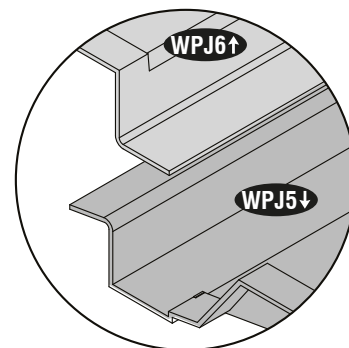
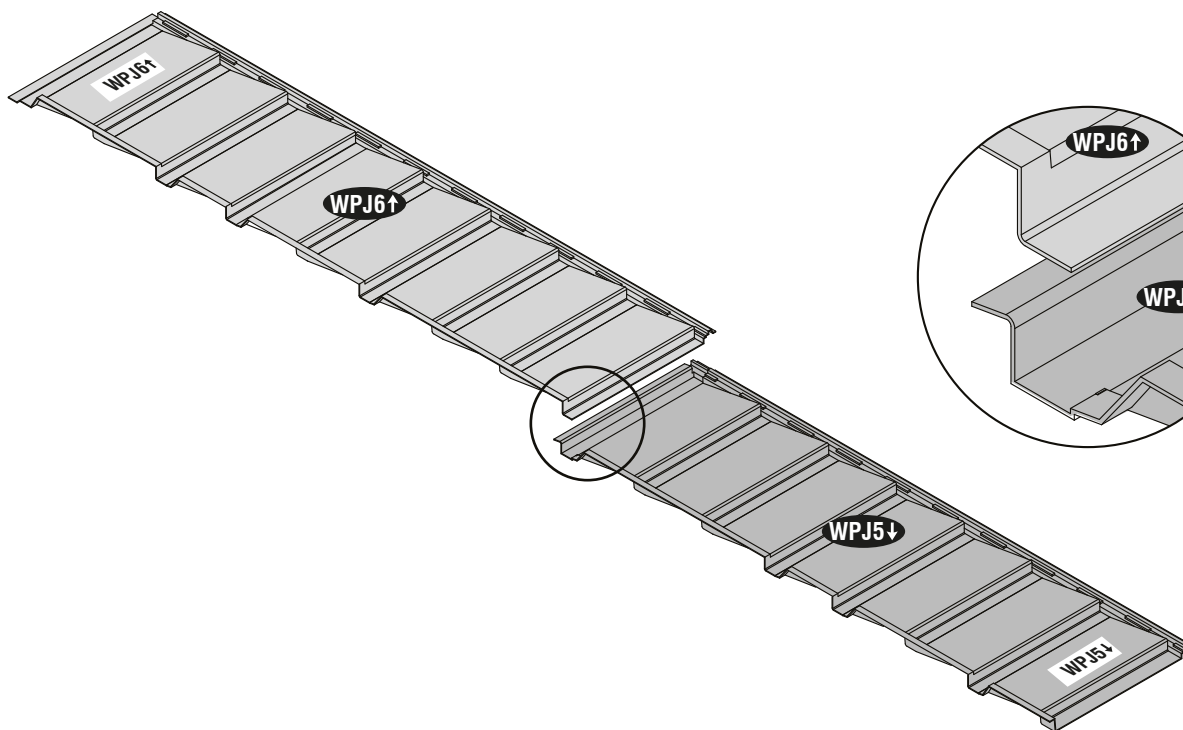
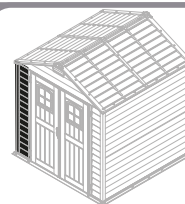
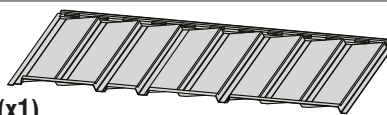

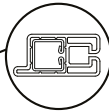
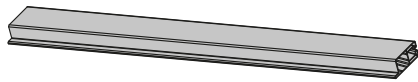

CLJ4 (x1)

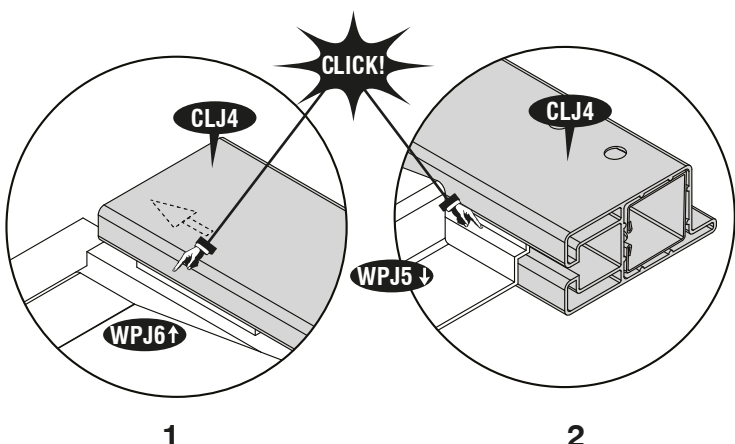
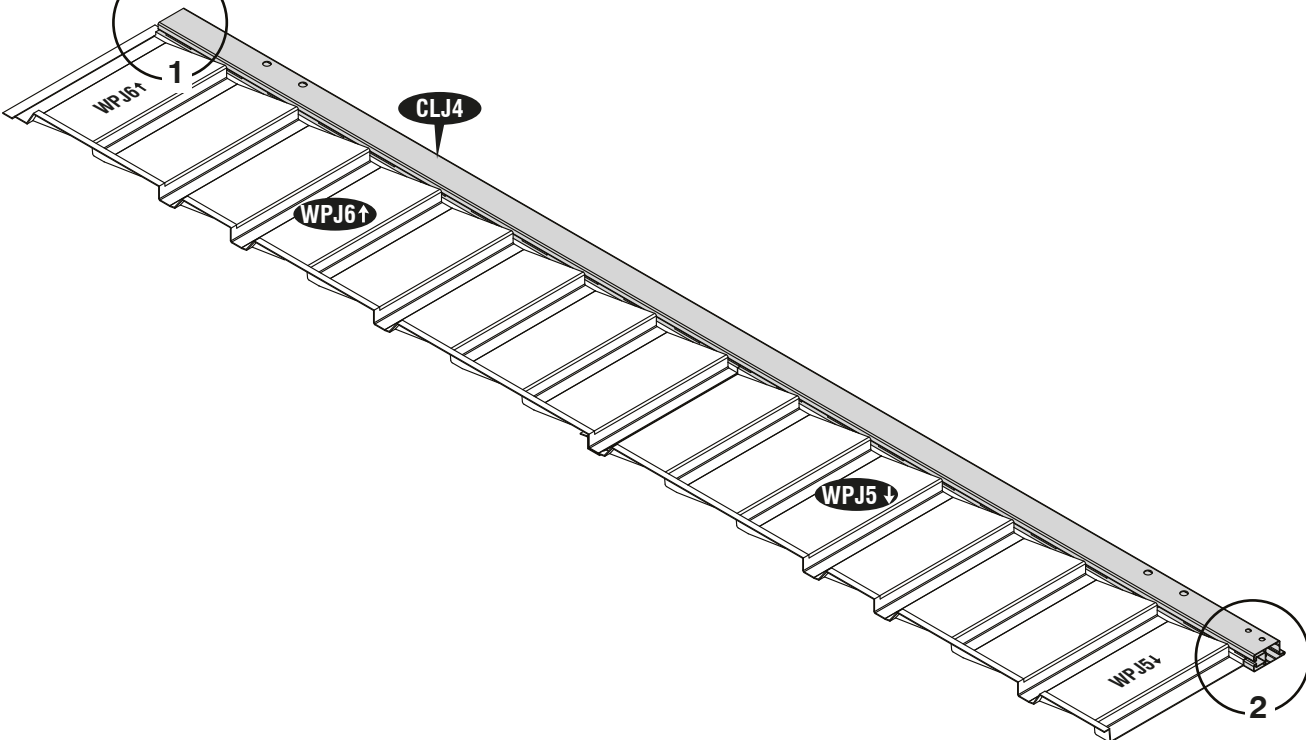
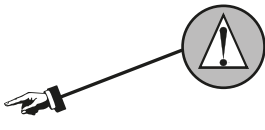
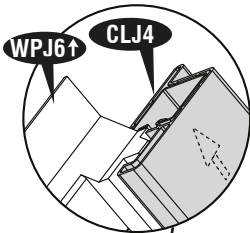
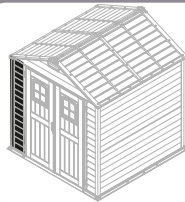

D

- EN Front Right Wall Pre-Assembly
FR Pré-assemblage de la paroi avant droite
DE Vormontage der vorderen rechten Wand
ES Premontaje de la pared delantera derecha
PT Pré-montagem da parede frontal direita
NL Voormontage rechtervoorwand
CS Předmontáž přední pravé stěny
SK Predná montáž na pravú stenu
SL Predmontaža sprednje desne stene
- HR Predmontaža prednjeg desnog zida
HU A jobb első fal előszerelése
SV Förmontering av höger vägg fram
IT Pre-assemblaggio parete anteriore destra
PL Wstępny montaż przedniej prawej ściany
RO Pre-asamblarea peretelui frontal drept
BG Пред-дясна стена Предварително сглобяване
TR Ön Sağ Duvar Ön Montajı

11

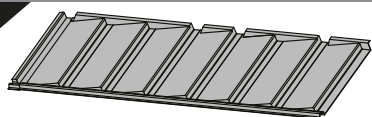

WPJ7↓ (x1)

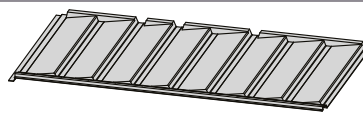

WPJ8↑ (x1)

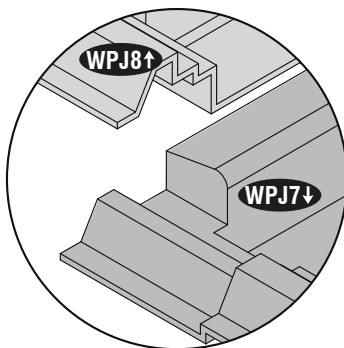
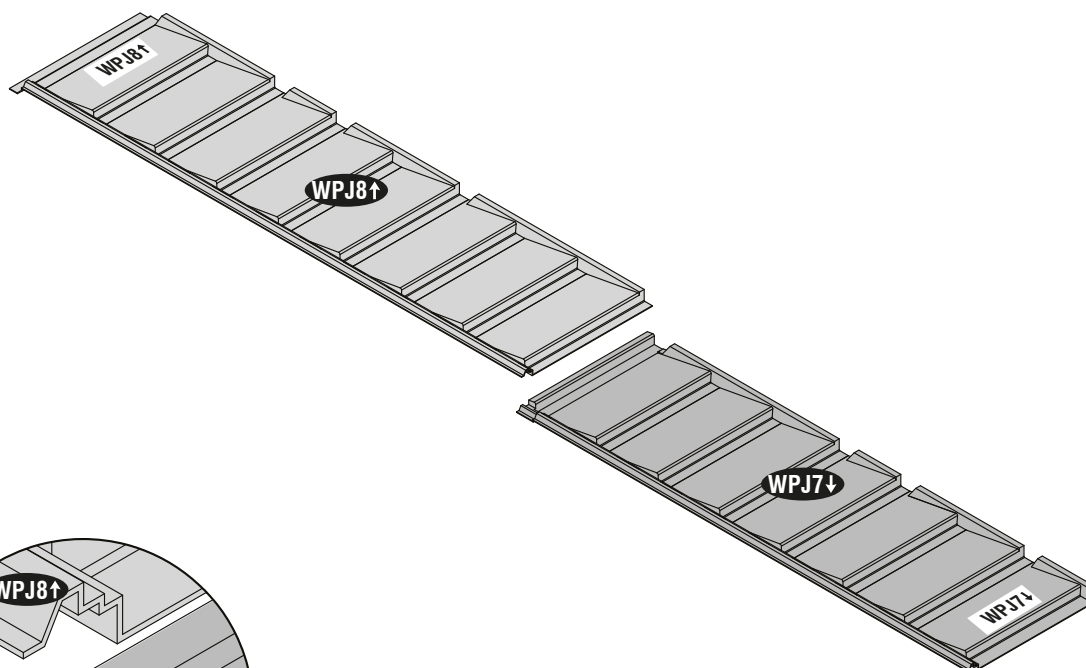
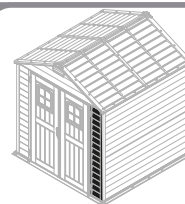

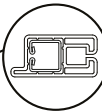
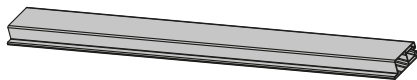

CLJ1 (x1)

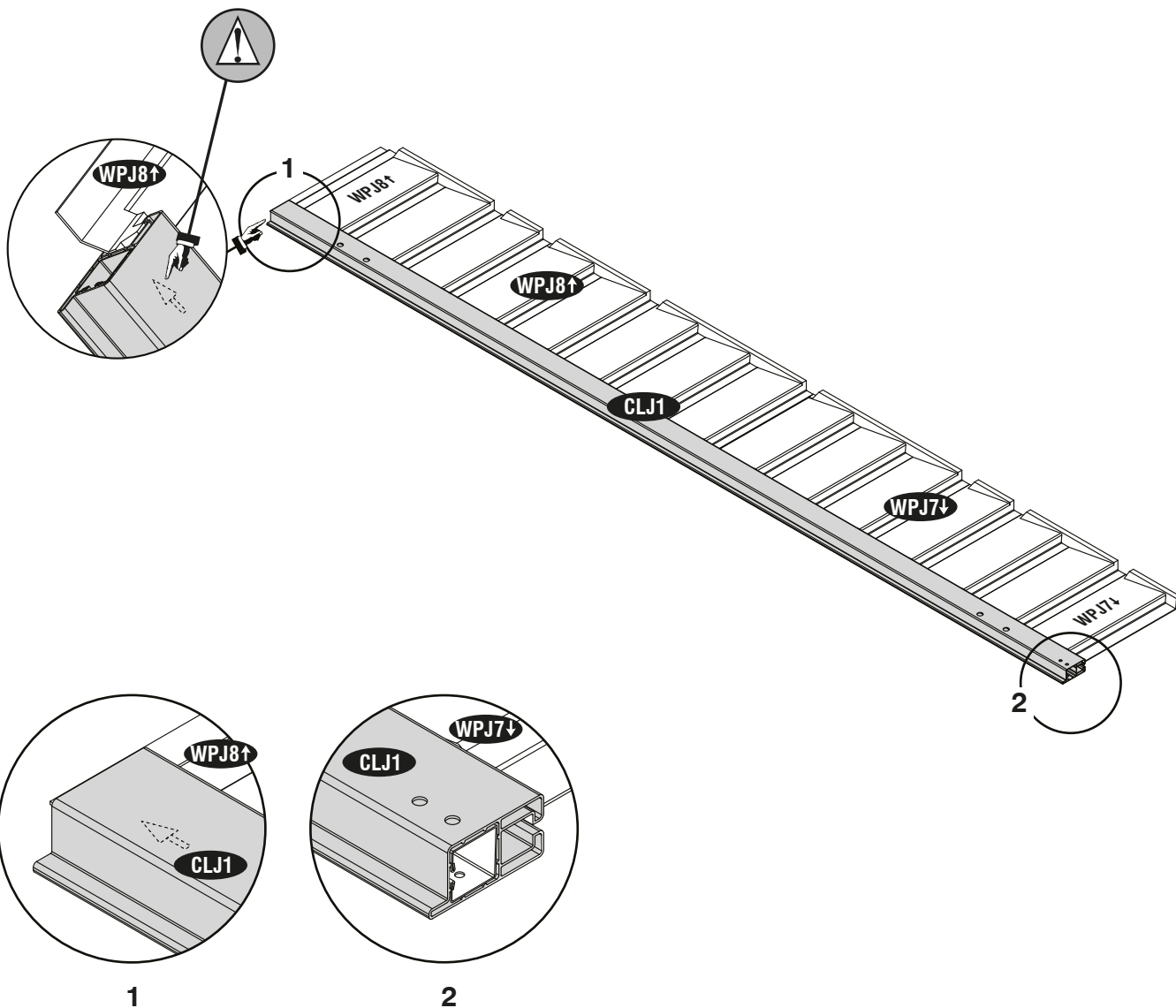
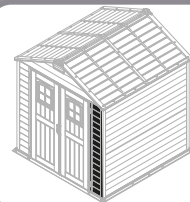

EN Front Roof Structure Assembly

FR Assemblage De La Structure Avant Du Toit

DE Vordere Dachkonstruktion Montage

ES Estructura de Asamblea de techo Frontal

E PT Armação da Estrutura do Telhado Frontal

NL Voorste dakconstructie montage kit

CS Montážní souprava přední střešní konstrukce

SK Montáž konštrukcie prednej strechy

SL Sestavni Del Prednje Strešne Konstrukcije

HR Prednja sklopa krovne konstrukcije

HU Első tetőszerkezet szerelvény

SV Frammonterad takkonstruktion

IT Assemblea anteriore tetto della struttura

PL Montaż konstrukcji dachu przedniego

RO Frontul șarpanta Adunarea

BG Предна покривна конструкция събрание

TR Ön Çatı Yapısı Koamplesi

13

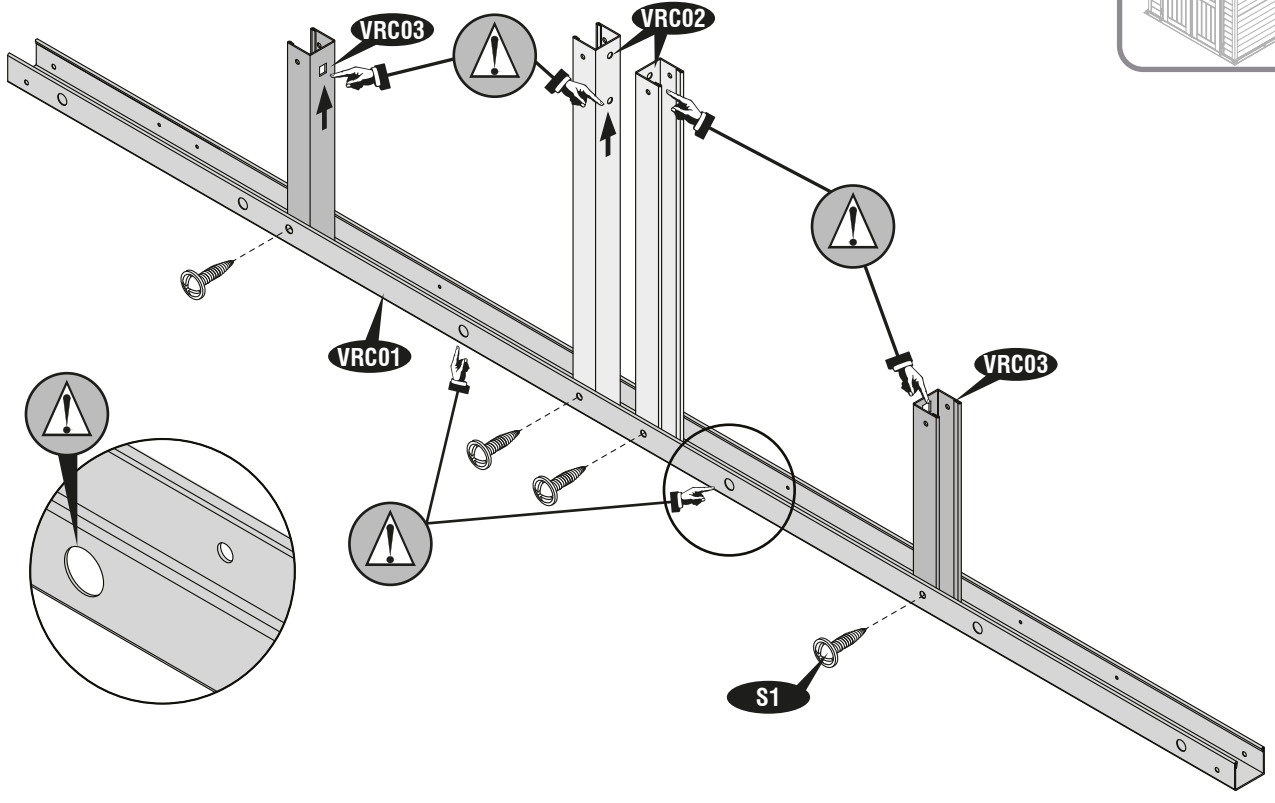
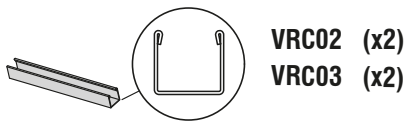
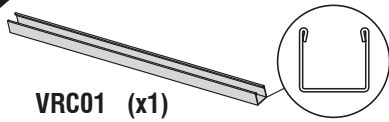

14

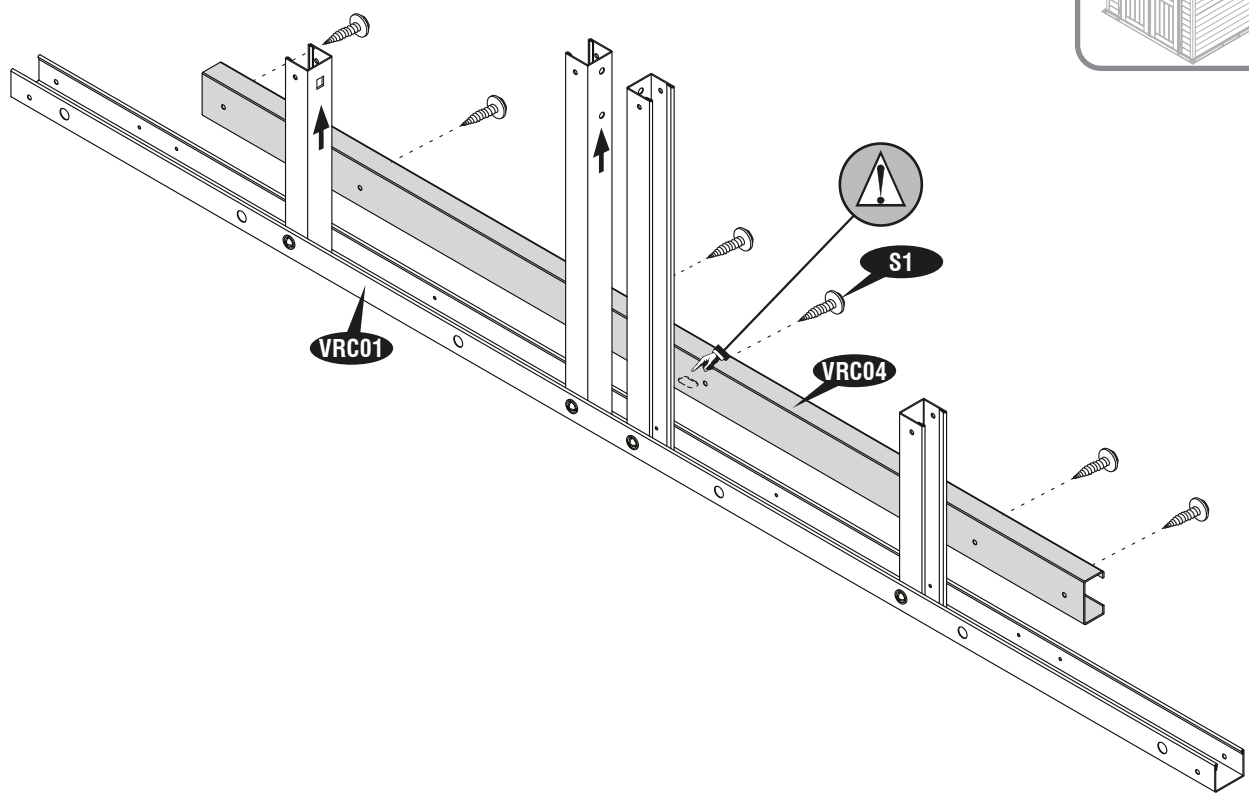
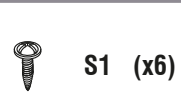
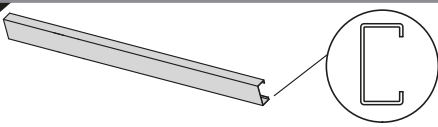

15

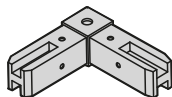

RJ (x2)



S1 (x2)

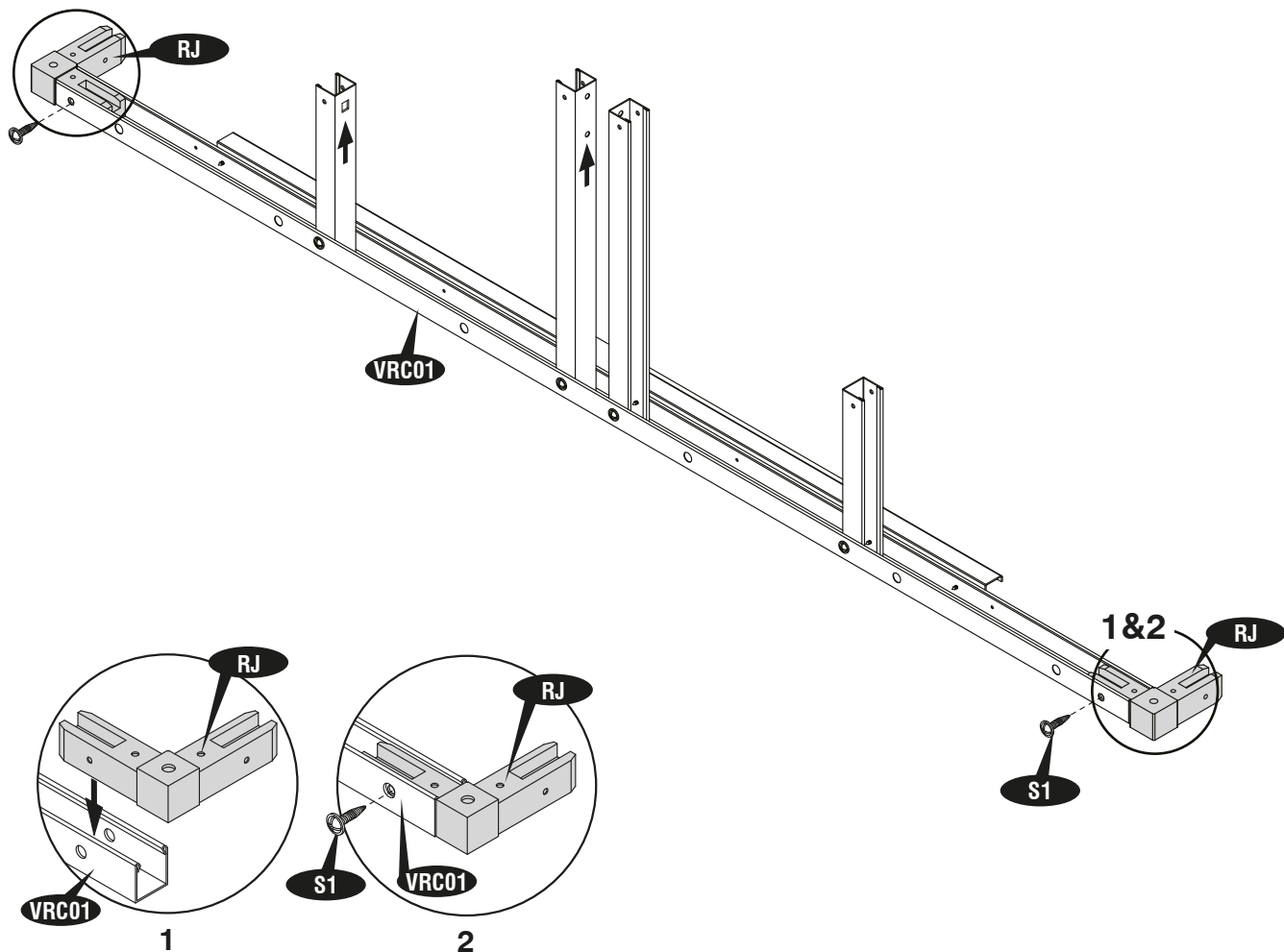
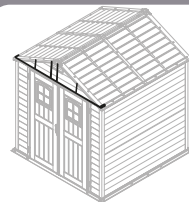

EN Back Roof Structure Assembly

FR Assemblage De La Structure Arriere Du Toit

DE Hintere Dachkonstruktion Montage

ES Estructura de montaje de techo trasera

F **PT** Armação da Estrutura do Telhado Traseiro

NL Achter dakconstructie montage kit

CS Montážní souprava zadní střešní konstrukce

SK Zadné strešné konštrukcie Montáž

SL Sestavni Del Zadnje Strešne Konstrukcije

HR Sastavni dio krovne strukture

HU Vissza Tetőszerkezet szerelvény

SV Bakre takkonstruktion

IT Assembla Struttura posteriore del tetto

PL Montaż tylnej konstrukcji dachu

RO Structura de asamblare Înnapoi acoperiş

BG Структура събиране Обратно Покрив

TR Arka Çatı Yapısı Kompleksi

16

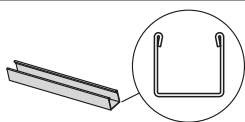
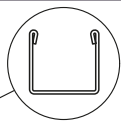
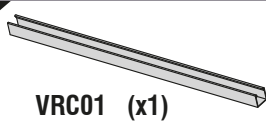

S1 (x8)

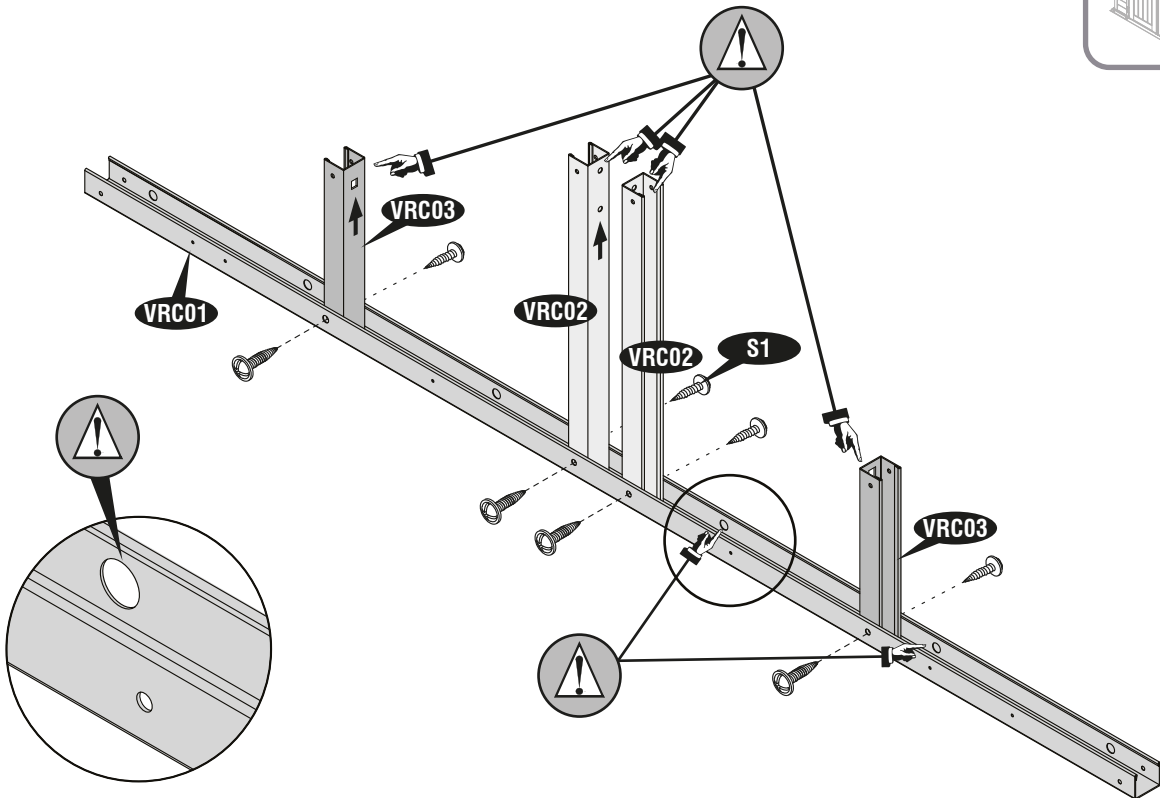
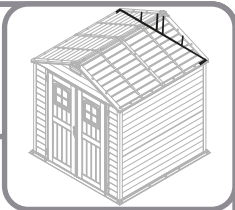

17

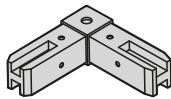

RJ (x2)



S1 (x2)

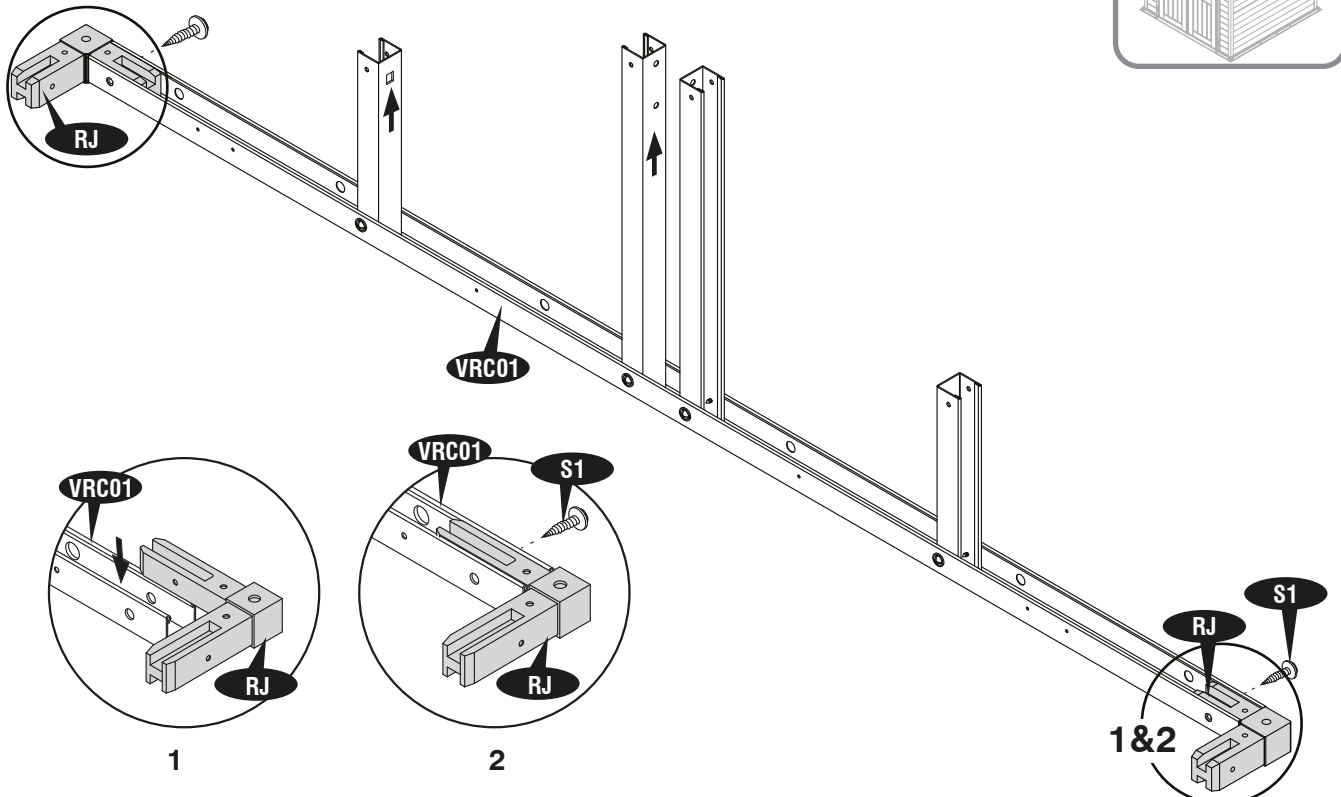



- 3**
- | | | |
|------------------------|-------------------------|------------------------|
| EN Walls Assembly | CS Montáž stěn | IT Assemblaggio pareti |
| FR Assemblage des murs | SK Montáž stien | PL Montaż ścian |
| DE Wände Montage | SL Montaža zidov | RO Adunarea zidurilor |
| ES Montaje de paredes | HR Montaža zidova | BG Монтаж на стени |
| PT Montagem de paredes | HU Falak összeszerelése | TR Duvar Montajı |
| NL Muren montage | SV Vägghmontering | |

- | | | |
|-----------------------|-----------------------------------|-----------------------------------|
| EN Parts needed | CS Potřebné součásti | IT Parti occorrenti |
| FR Pièces nécessaires | SK Potrebne časti | PL Niezbędne elementy |
| DE Benötigte Teile | SL Dele, ki jih boste potrebovali | RO Elementele componente necesare |
| ES Piezas necesitadas | HR Dijelovi potreban | BG Необходими части |
| PT Peças Necessárias | HU Szükséges részek | TR Gerekli parçalar |
| NL Onderdelen nodig | SV Delar som behövs | |

A	1	S1	12
B	2	S5	16
C	1		
D	1		
E	1		
BPS	16		



1

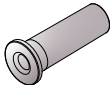

BPS (x16)

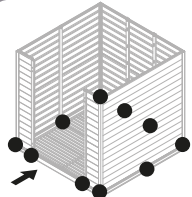

- EN** Insert the Sleeves (**BPS**) into all holes of the Base Pallet as shown in fig.
- FR** Insérez les manchons (**BPS**) dans tous les trous de la palette de base comme indiqué sur la fig.
- DE** Führen Sie die Hülsen (**BPS**) wie in Abb. 1 gezeigt in alle Löcher der Basispalette ein.
- ES** Inserte las mangas (**BPS**) en todos los orificios de la plataforma base como se muestra en la fig.
- PT** Insira as mangas (**BPS**) em todos os orifícios da paleta base, conforme mostrado na fig.
- NL** Steek de hulzen (**BPS**) in alle gaten van de basispallet zoals getoond in afb.
- CS** Vložte pouzdra (**BPS**) do všech otvorů základní palety, jak je znázorněno na obr.
- SK** Vložte objímky (**BPS**) do všetkých otvorov základnej palety, ako je to znázornené na obr.
- SL** Ročice (**BPS**) vstavite v vse luknje osnovne palete, kot je prikazano na sl.
- HR** Umetnite čaure (**BPS**) u sve rupe na osnovnoj paleti kako je prikazano na sl.
- HU** Helyezze a hüvelyeket (**BPS**) az alapraklap összes lyukába, amint az a 2. ábrán látható.
- SV** För in hylsorna (**BPS**) i alla hål på baspallen enligt fig.
- IT** Inserire gli Sleeves (**BPS**) in tutti i fori del Base Pallet come mostrato in fig.
- PL** Włóż tuleje (**BPS**) do wszystkich otworów palety podstawowej, jak pokazano na rys.
- RO** Introduceți manșoanele (**BPS**) în toate găurile paletului de bază așa cum se arată în fig.
- BG** Поставете втулките (**BPS**) във всички отвори на основния палет, както е показано на фиг.
- TR** Inserire gli Sleeves (**BPS**) in tutti i fori del Base Pallet come mostrato in fig.

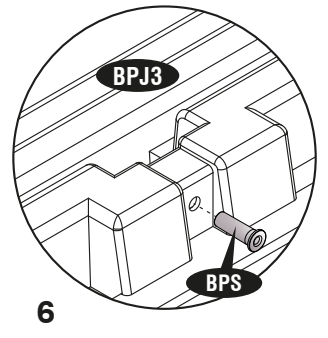
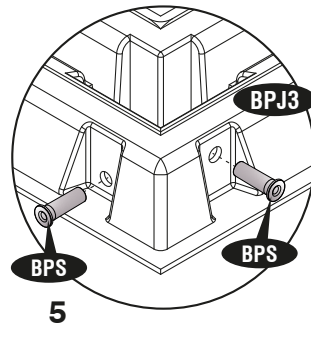
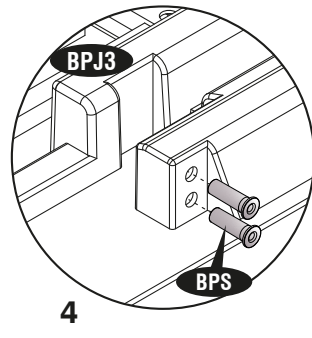
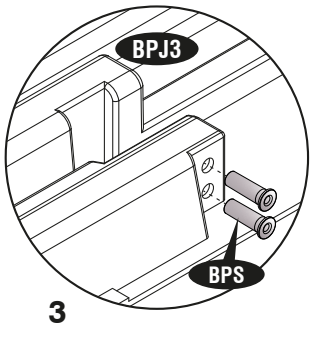
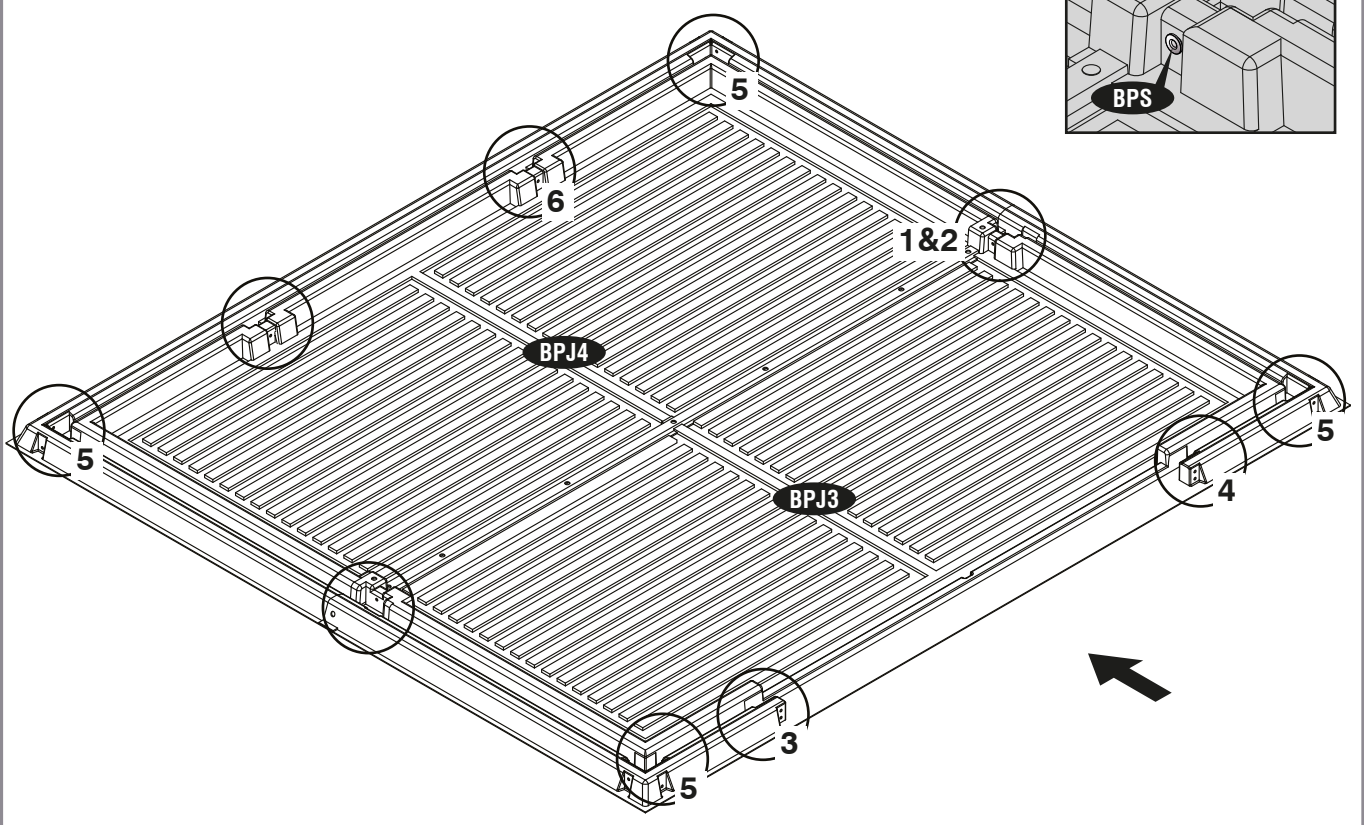
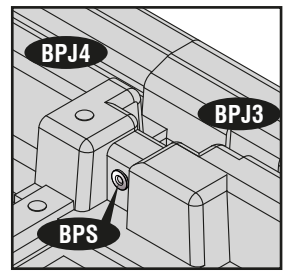
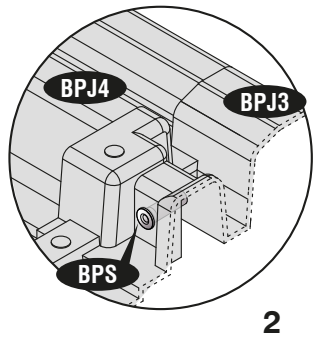
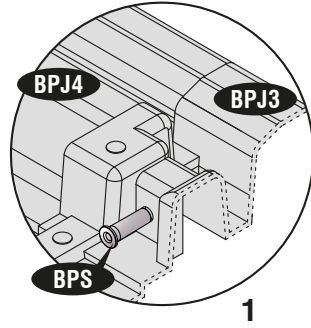

2

A (x1)

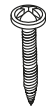

S5 (x1)

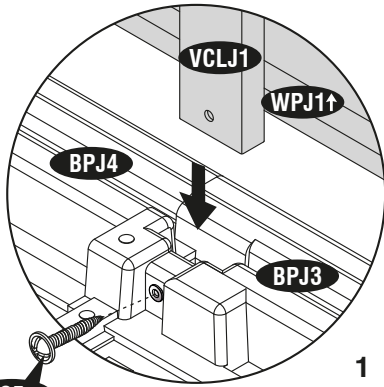
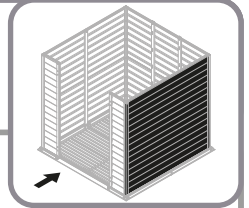

1

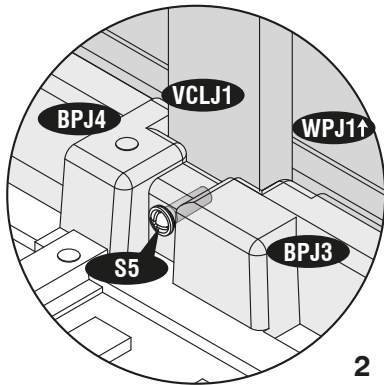

2

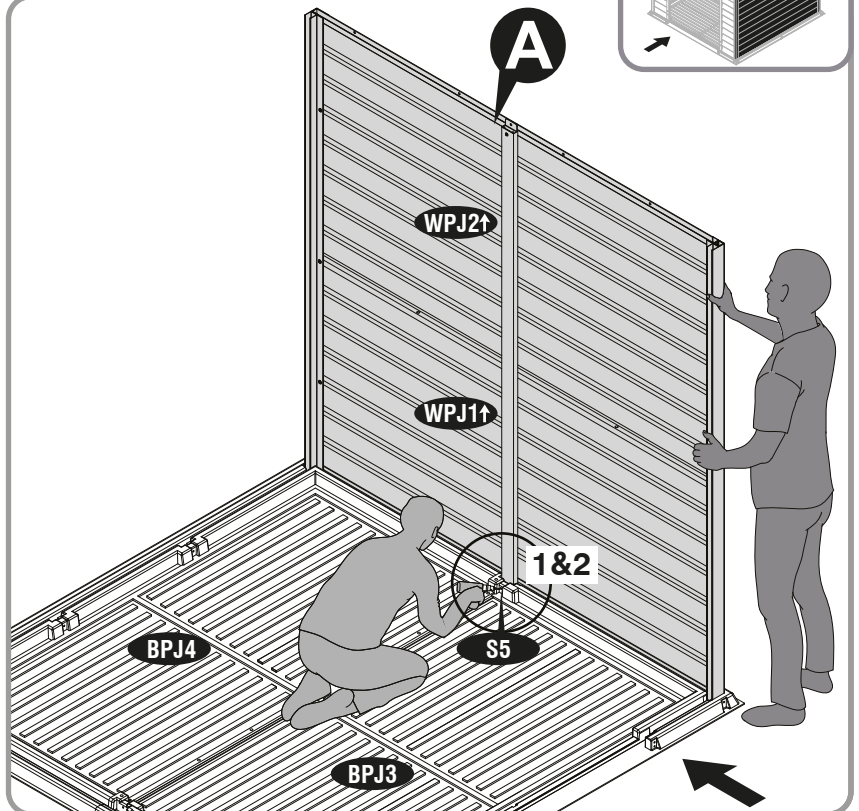

3



S5 (x4)

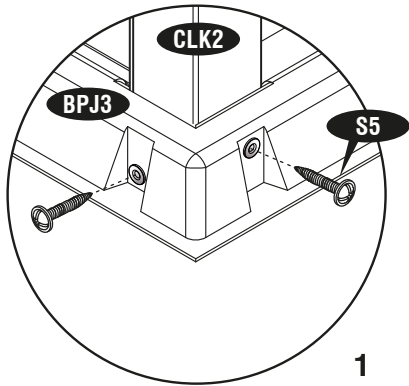
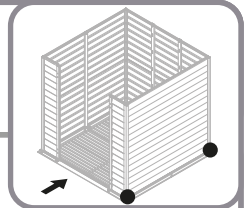

1

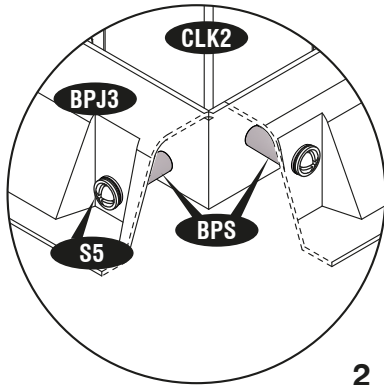

2

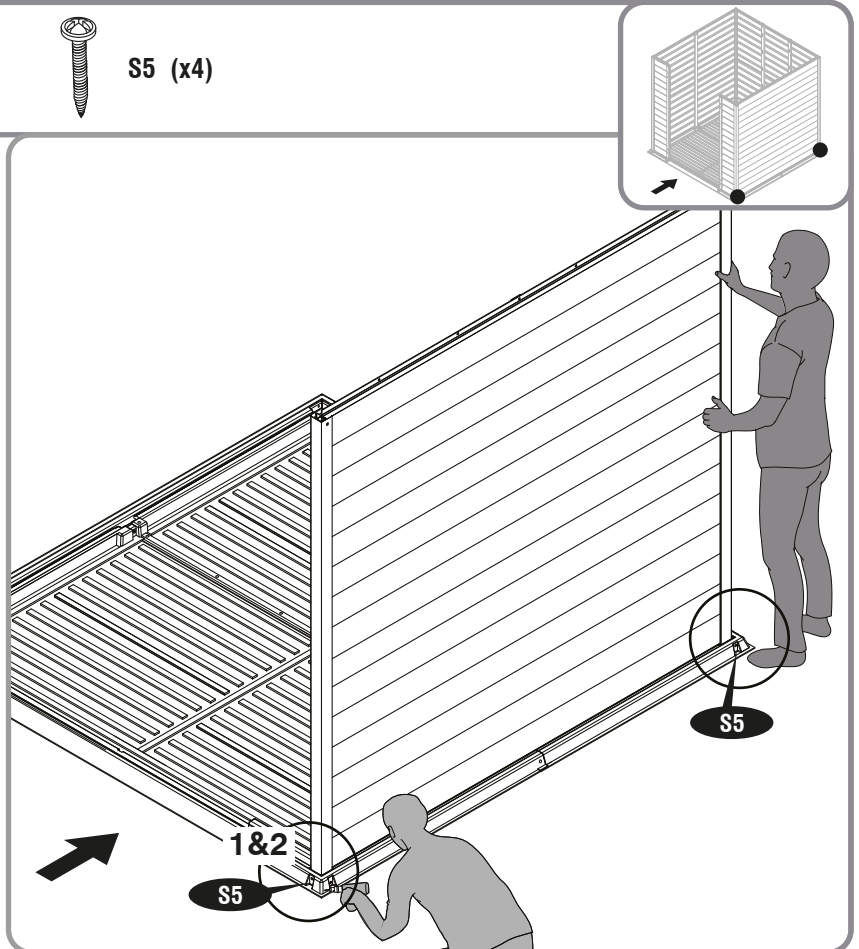

4

D (x1)



S5 (x2)

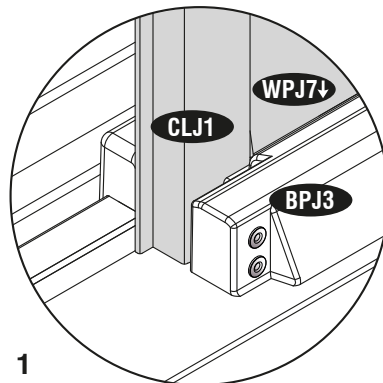
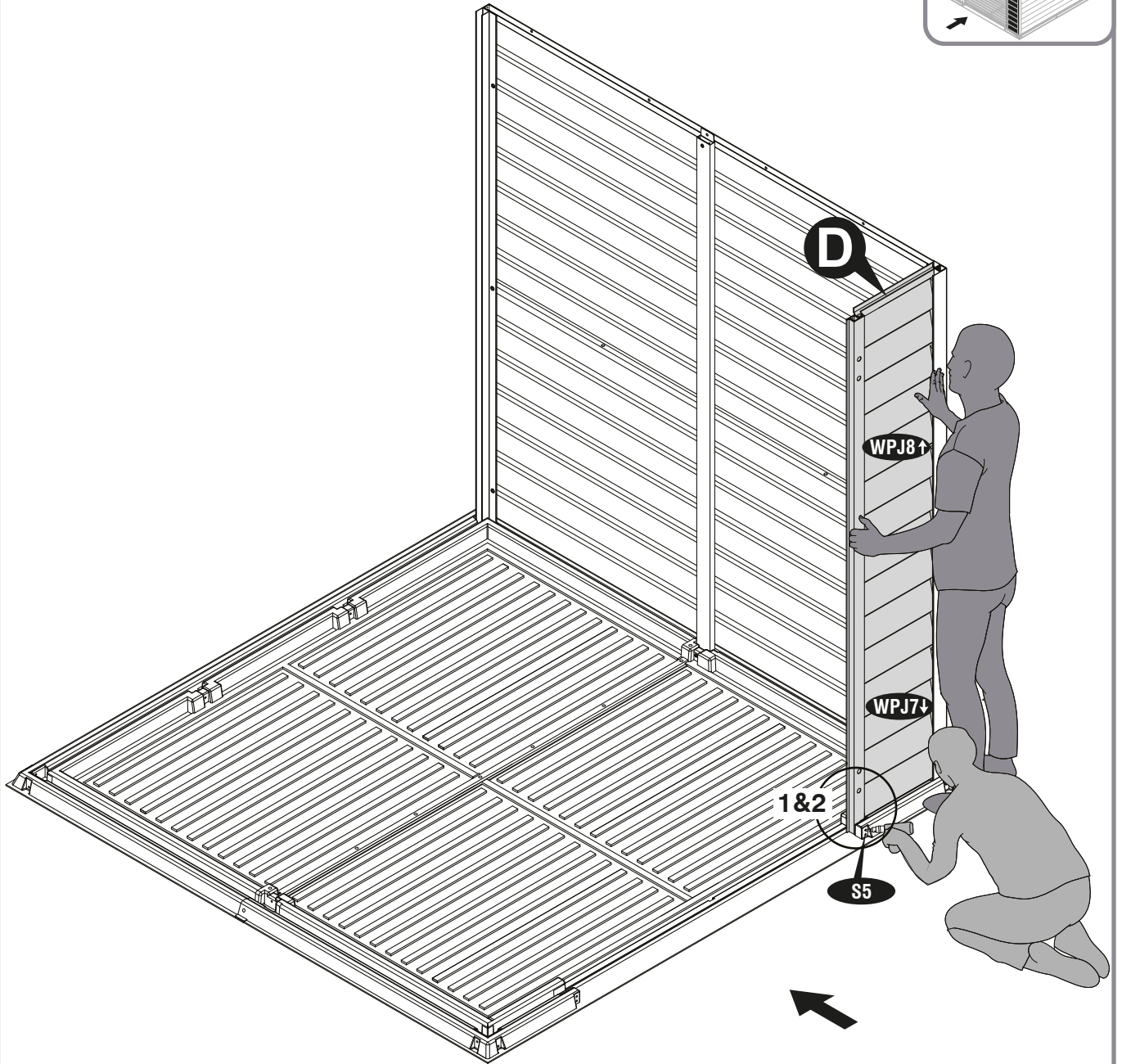
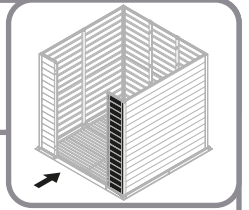

1

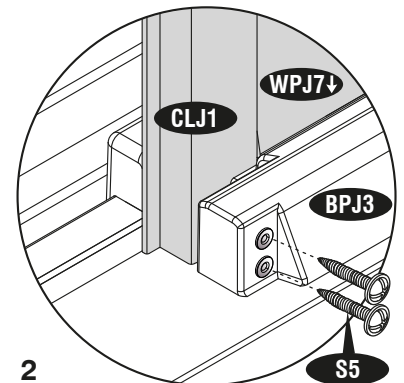

2

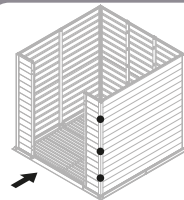

- EN** Ensure that these two faces are level before applying screw.
- FR** Assurez-vous que ces deux faces sont de niveau avant d'appliquer la vis.
- DE** Stellen Sie sicher, dass diese beiden Flächen eben sind, bevor Sie die Schraube anbringen.
- ES** Asegúrese de que estas dos caras estén niveladas antes de aplicar el tornillo.
- PT** Certifique-se de que essas duas faces estejam niveladas antes de aplicar o parafuso.
- NL** Zorg ervoor dat deze twee vlakken waterpas zijn voordat u de schroef aanbrengt.
- CS** Před použitím šroubu se ujistěte, že jsou tyto dvě strany v rovině.
- SK** Pred použitím skrutky sa uistite, že sú tieto dve strany vyrovnané.
- SL** Pred nalaganjem vijaka se prepričajte, da sta ti dve ravni poravnani.
- HR** Prije nanošenja vijka osigurajte da su ove dvije površine poravnate.
- HU** A csavar behelyezése előtt ellenőrizze, hogy ez a két oldal vízszintes-e.
- SV** Se till att dessa två ytor är plana innan du skruvar på.
- IT** Assicurarsi che queste due facce siano a livello prima di applicare la vite.
- PL** Przed wkręceniem śruby upewnij się, że te dwie powierzchnie są wyrównane.
- RO** Asigurați-vă că aceste două fețe sunt plane înainte de a aplica șurubul.
- BG** Уверете се, че тези две повърхности са изравнени, преди да поставите винт.
- TR** Vidayı uygulamadan önce bu iki yüzün aynı hizada olduğundan emin olun.

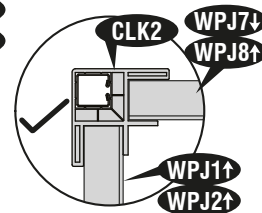
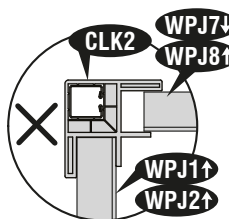
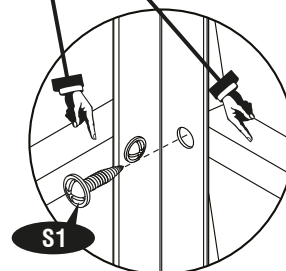
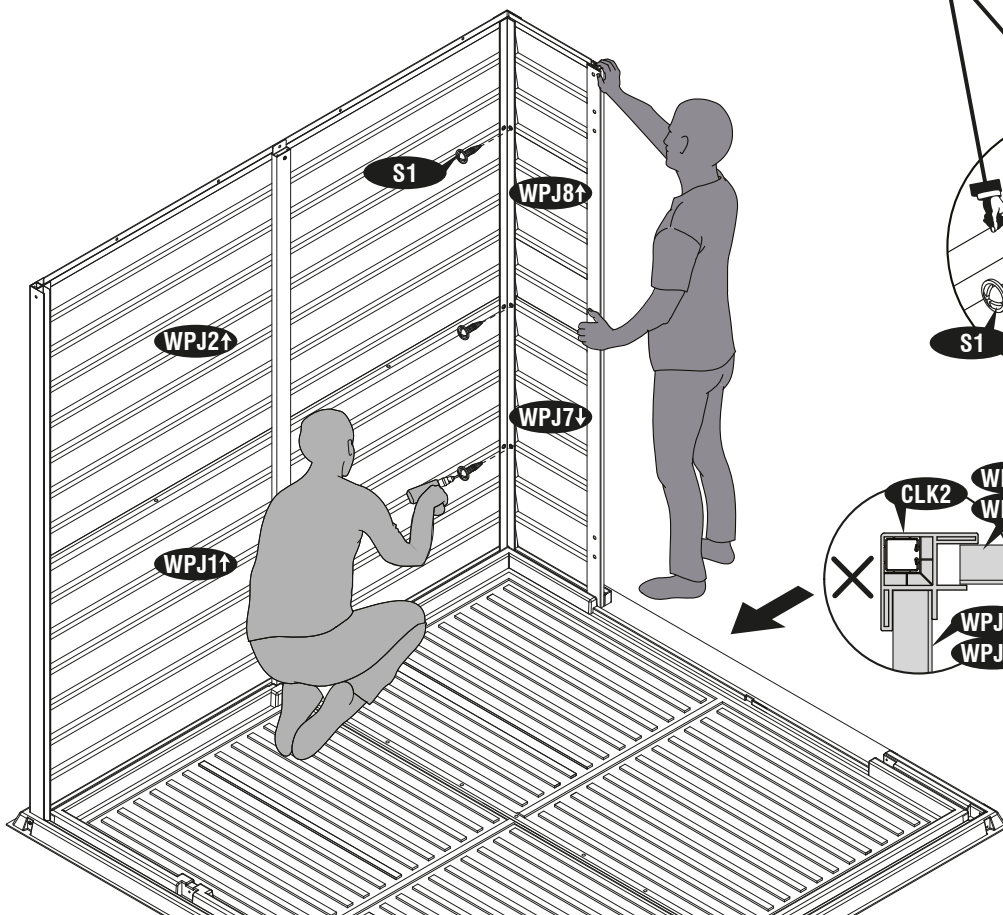

6

B (x1)

S1 (x1)

S5 (x2)

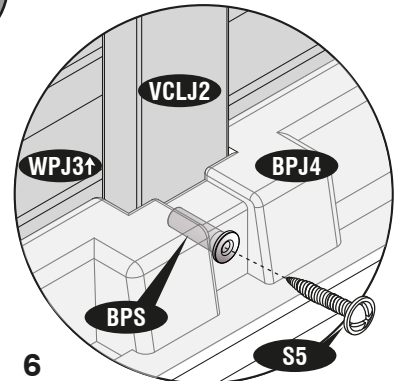
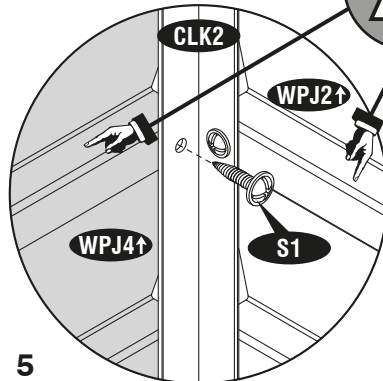
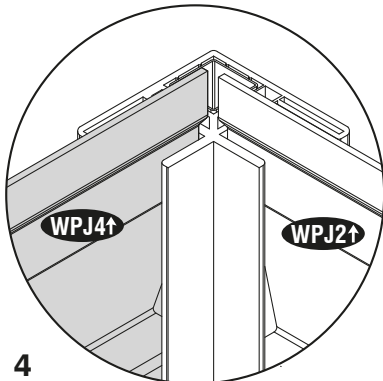
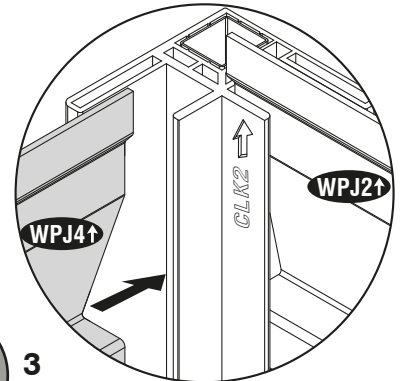
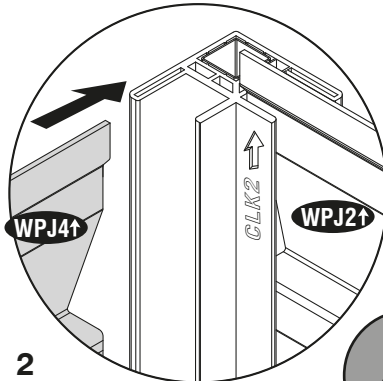
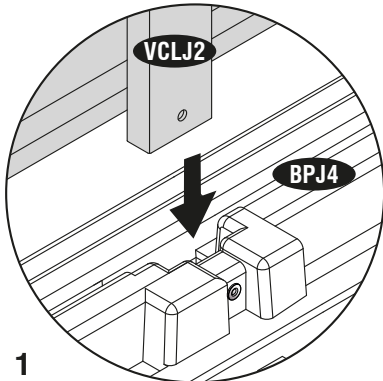
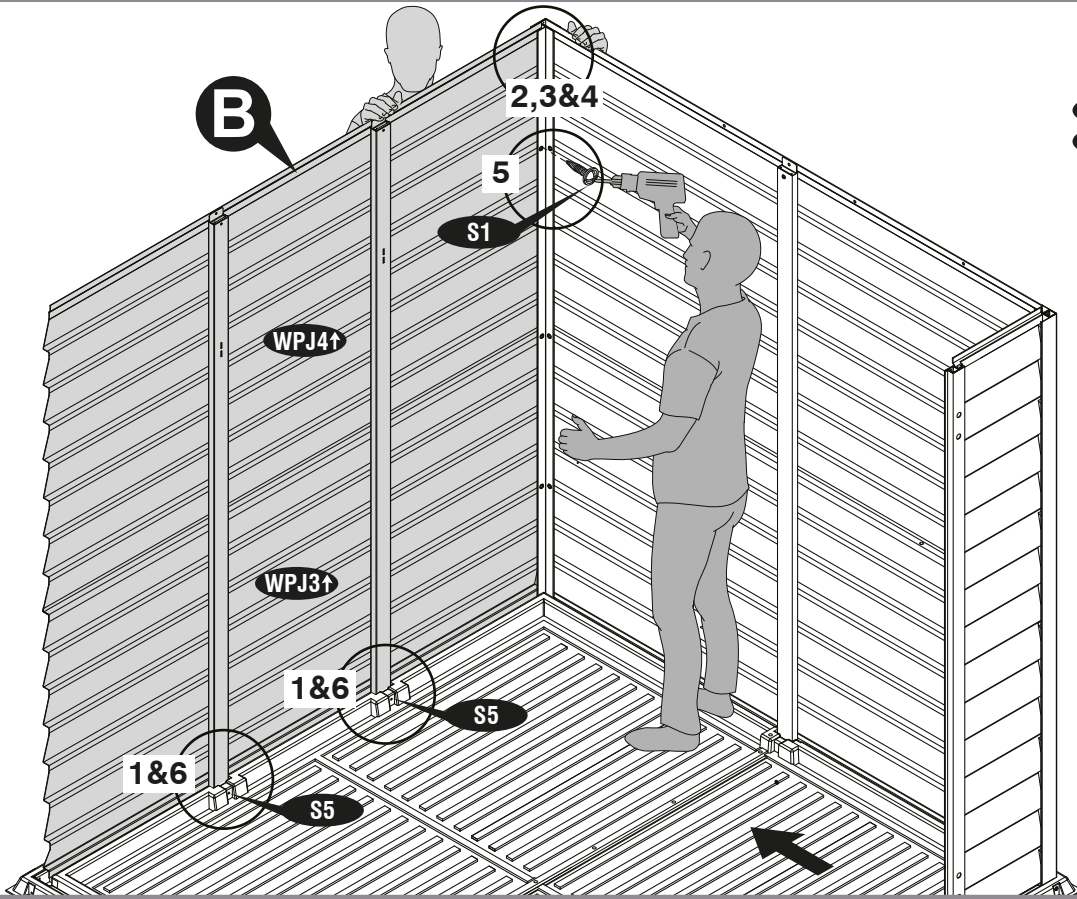
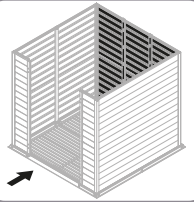

S1 (x2)

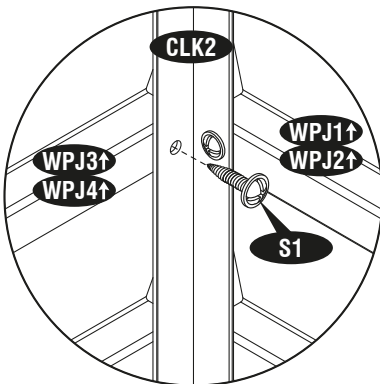
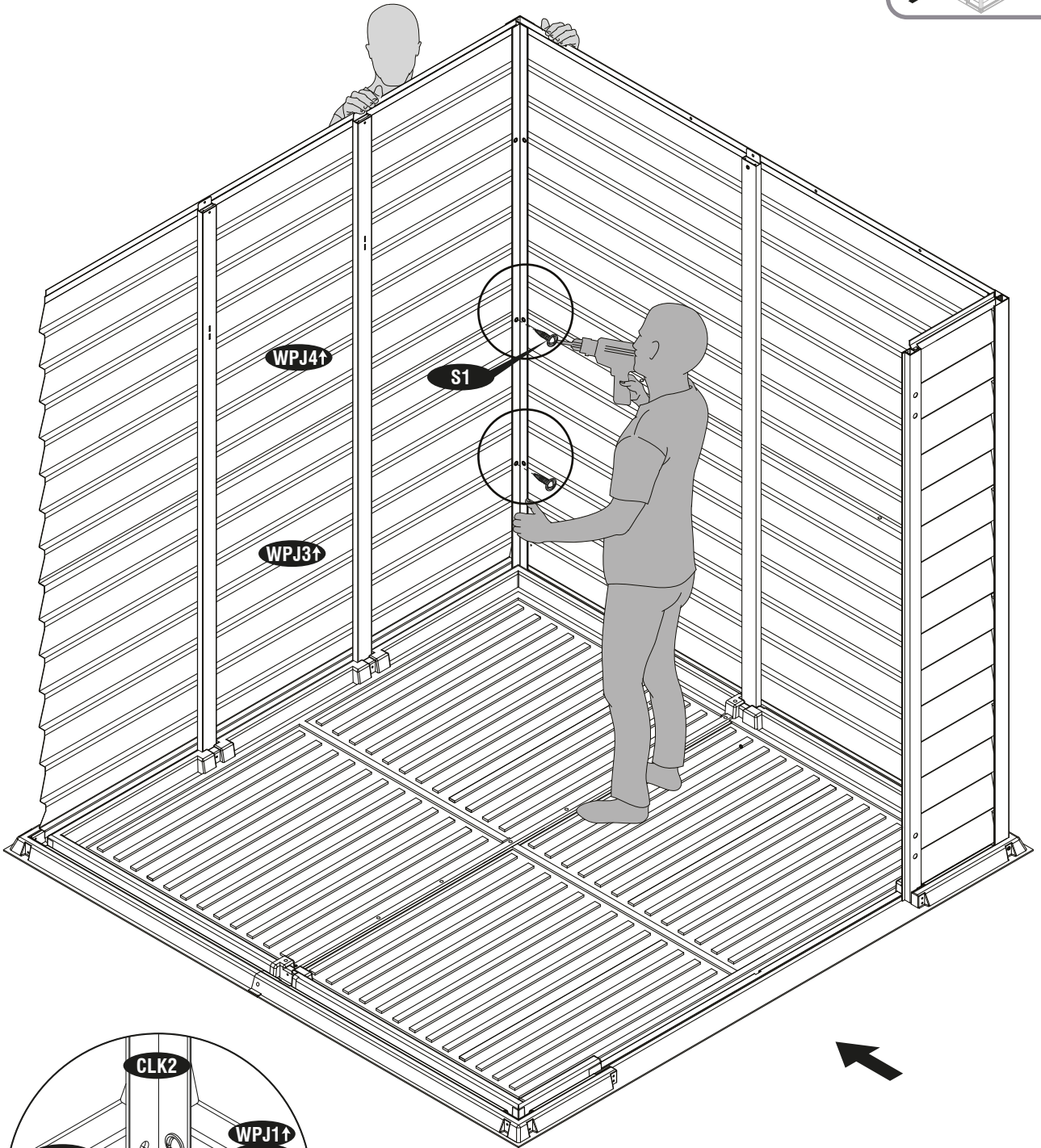
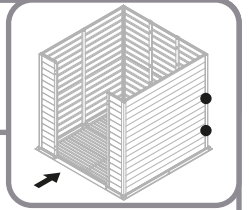

8

A (x1)



S1 (x1)

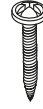

S5 (x1)

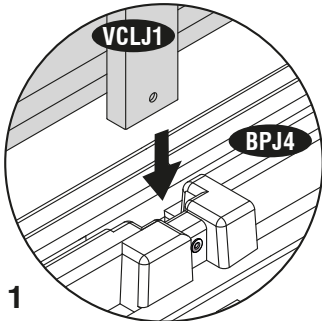
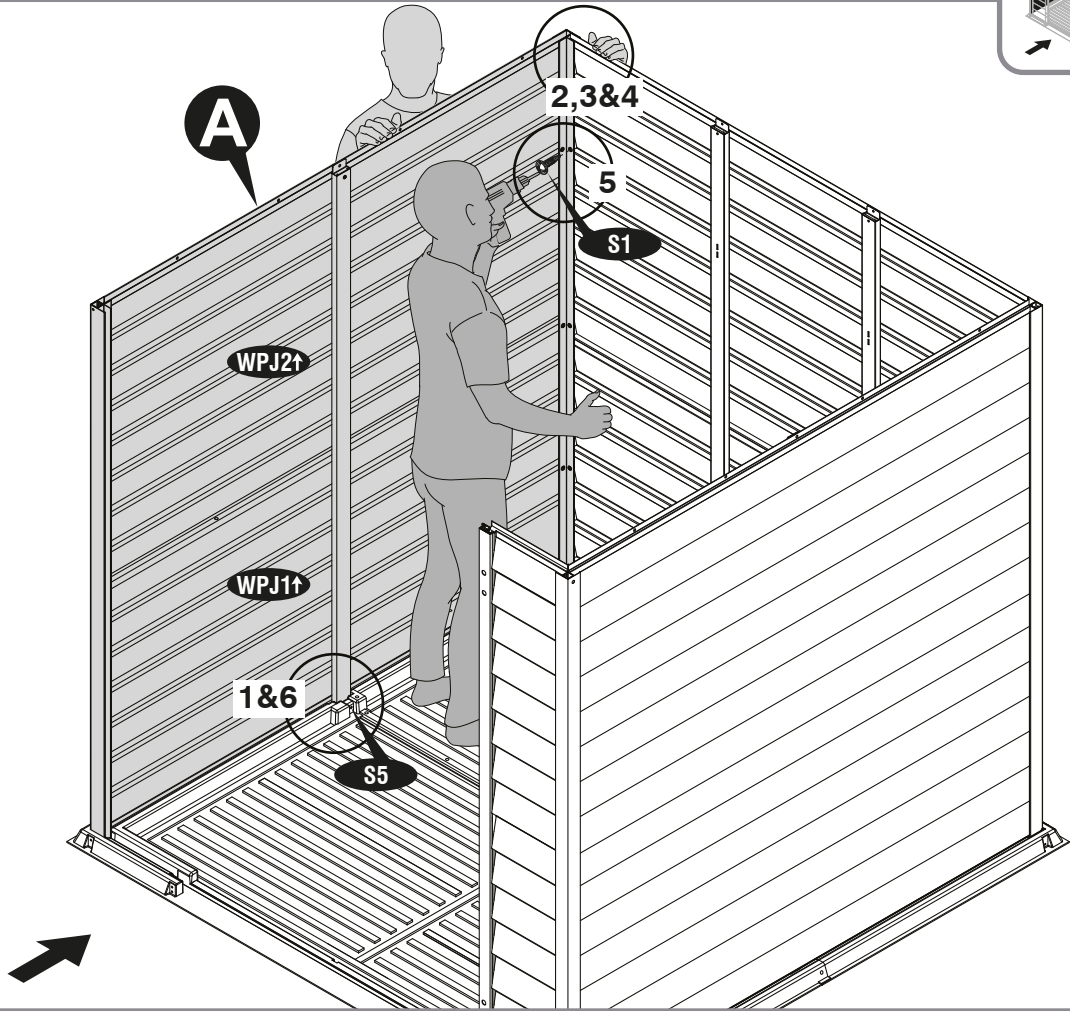
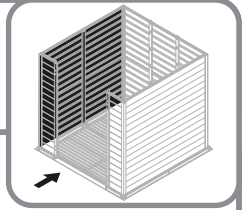

1

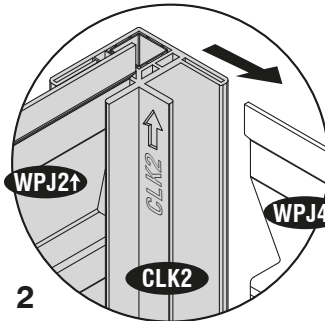

2

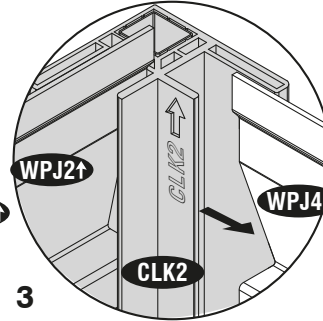

3

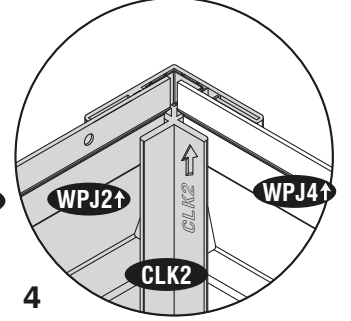

4

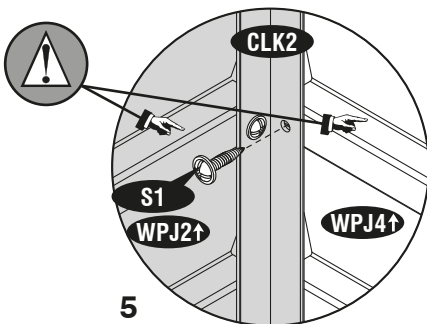

5

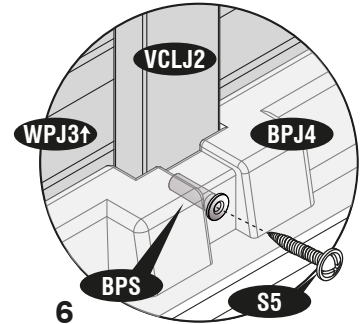

6

9



S5 (x4)

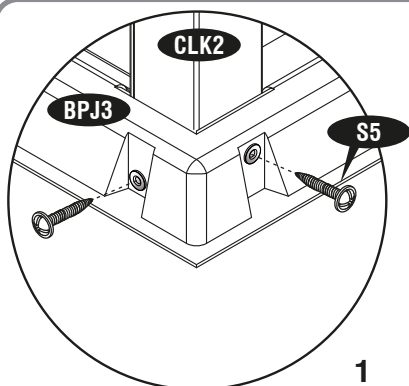
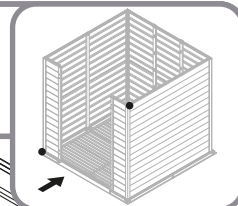

1

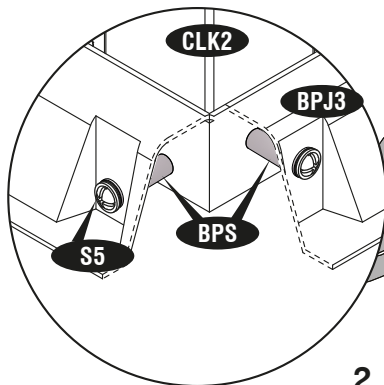

2

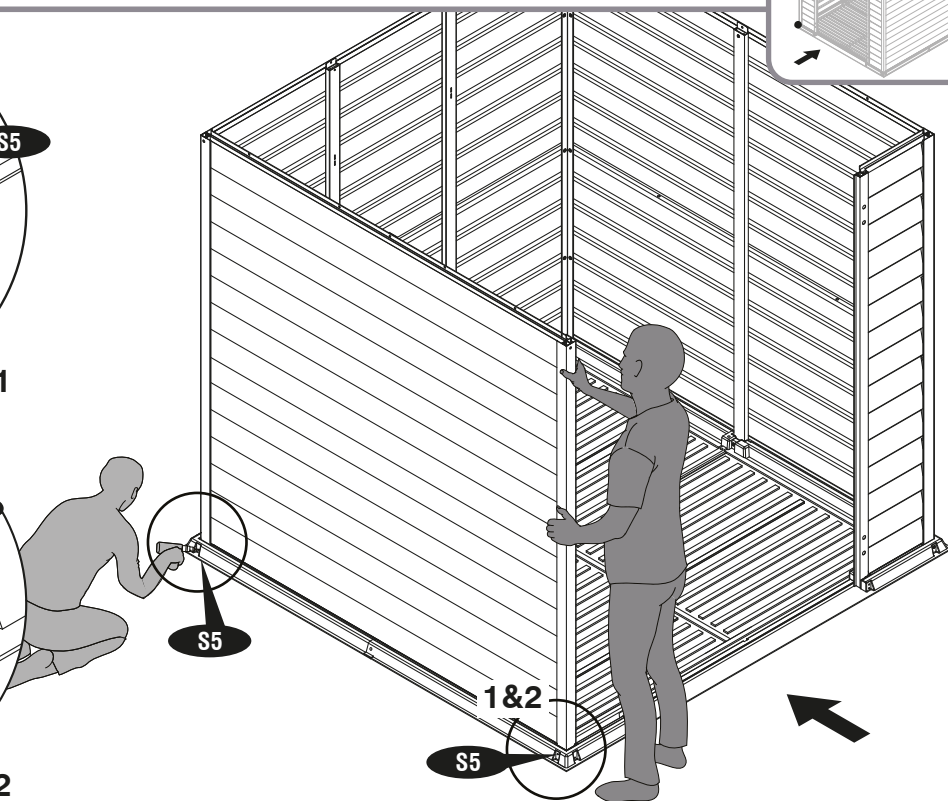

10



S1 (x2)

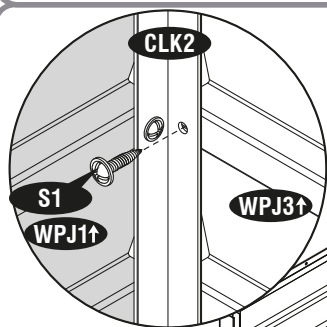
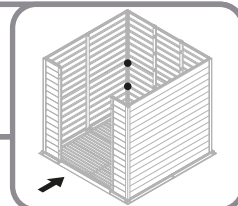

S1

WPJ1t

WPJ3t

S1

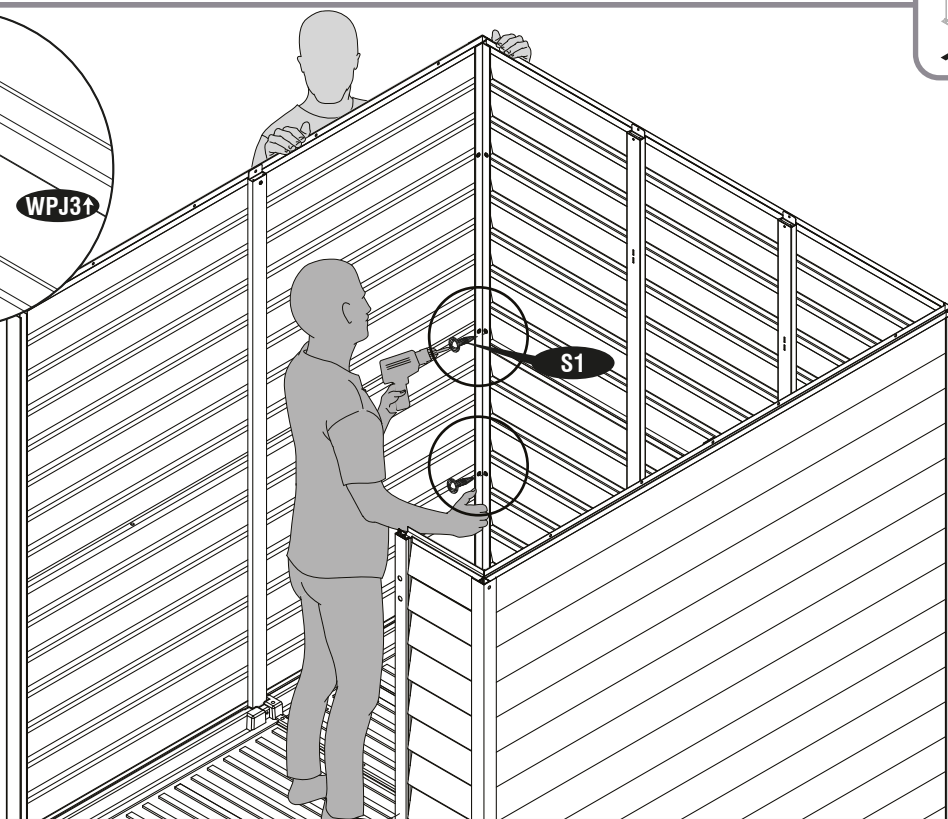

11

C (x1)



S5 (x2)

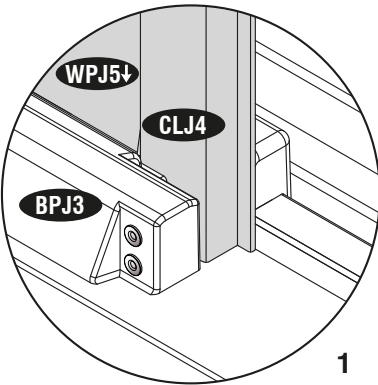
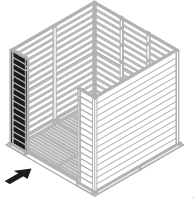

1

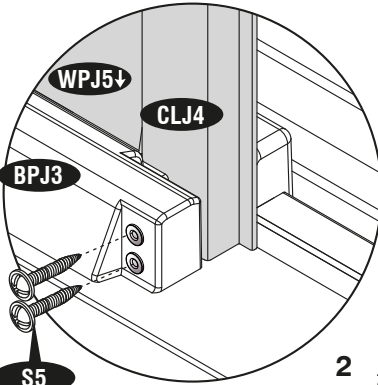

2

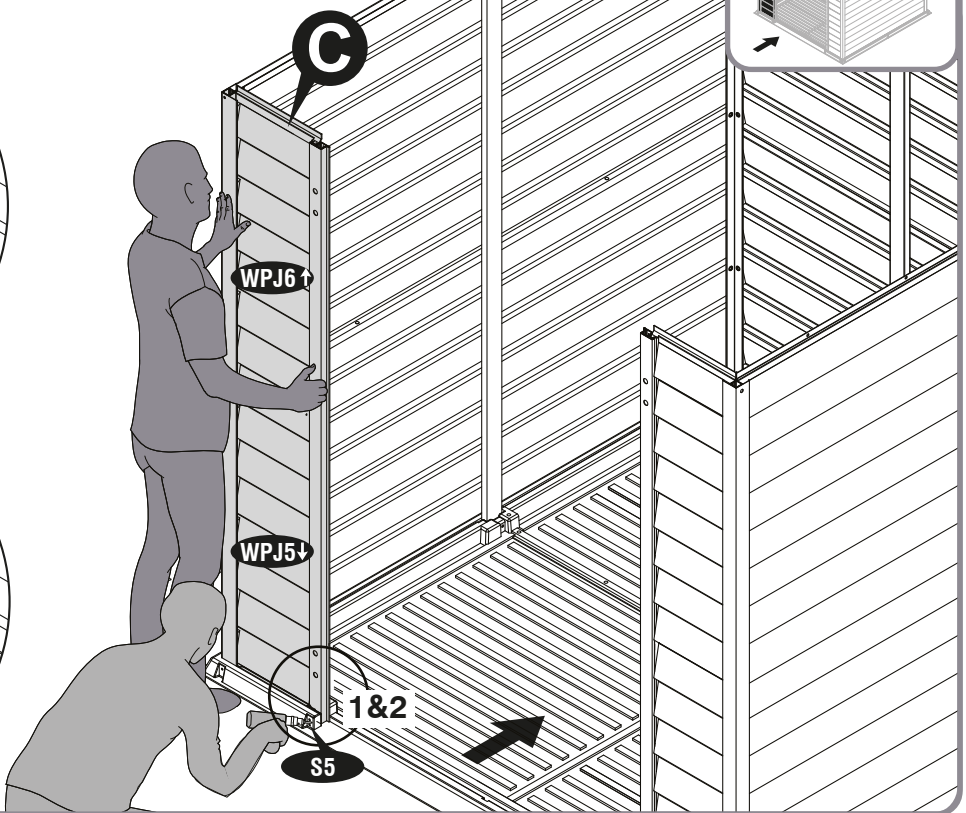

12



S1 (x3)

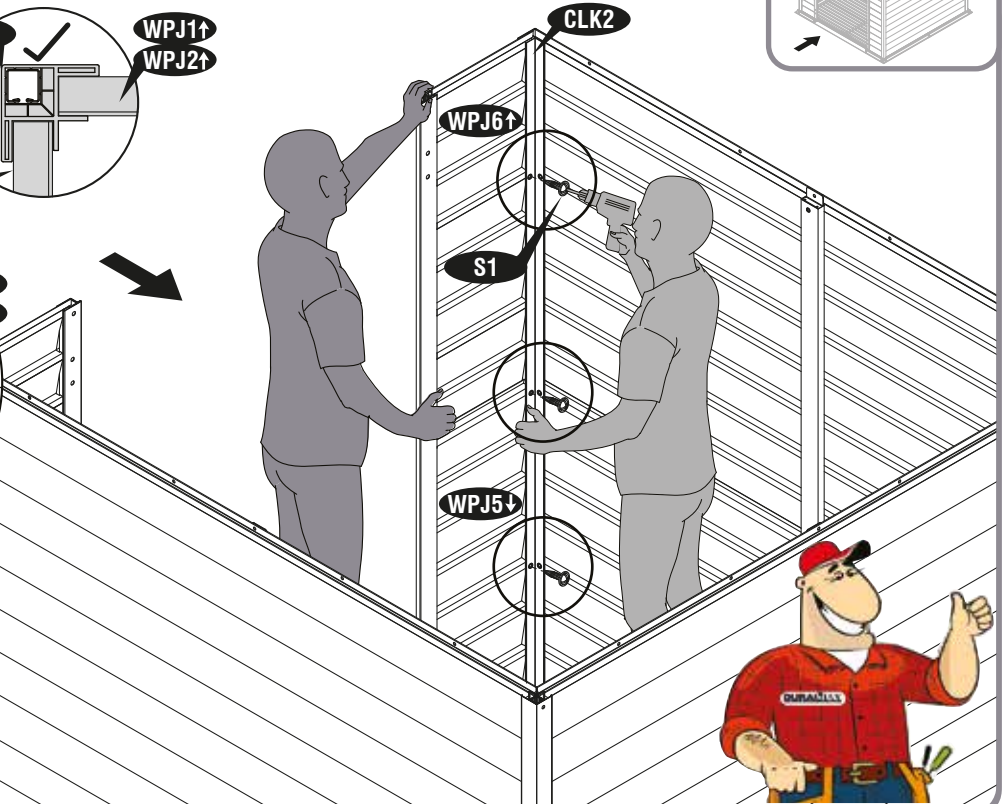
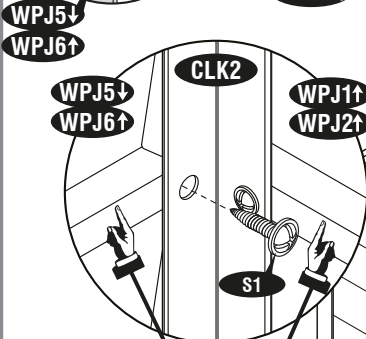
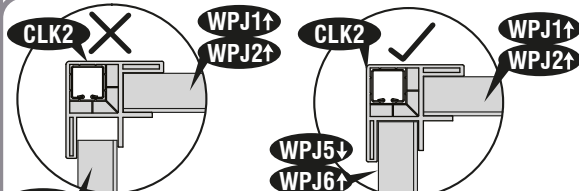
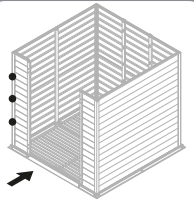

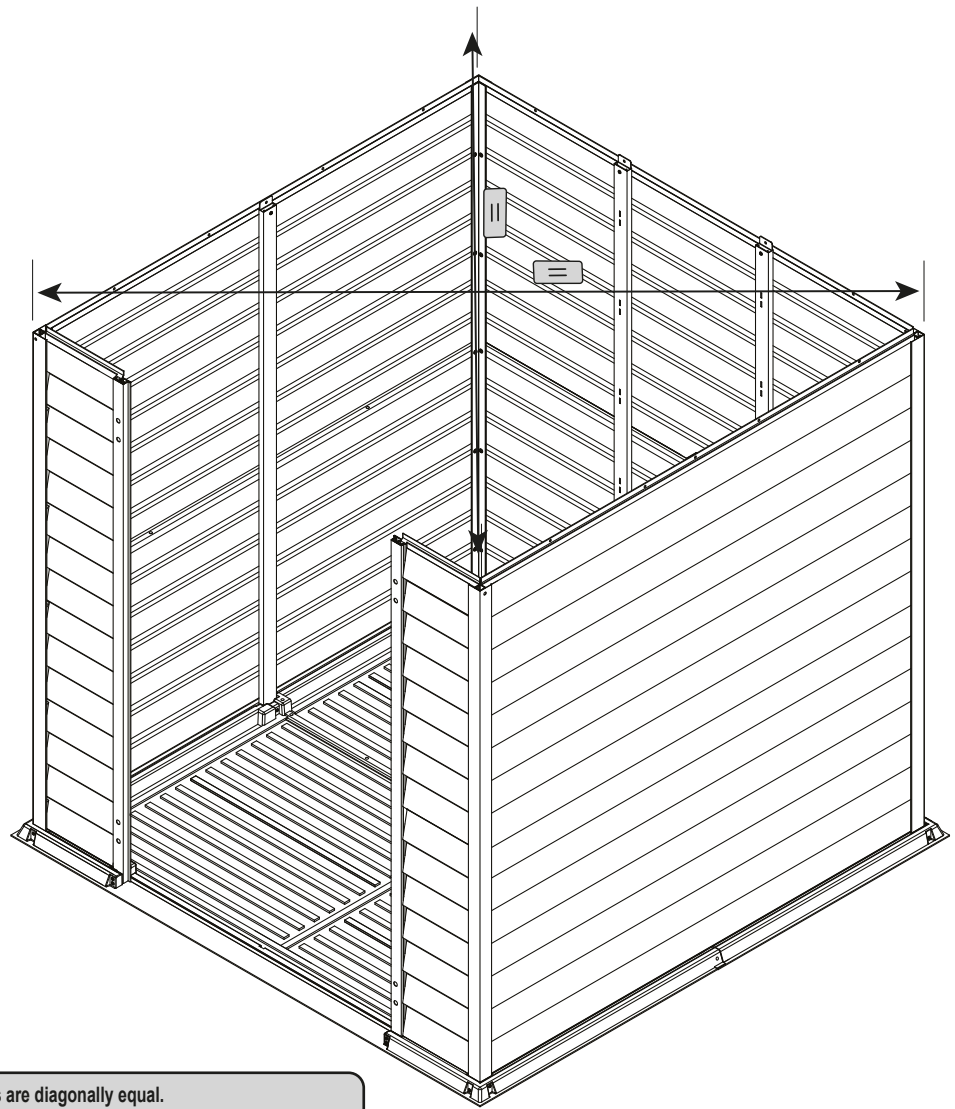

- EN** Make sure that the wall's top corners are diagonally equal.
- FR** Assurez-vous que les coins supérieurs du mur sont égaux en diagonale.
- DE** Stellen Sie sicher, dass die oberen Ecken der Wand diagonal gleich sind.
- ES** Asegúrate de que las esquinas superiores de la pared sean diagonalmente iguales.
- PT** Certifique-se de que os cantos superiores da parede sejam diagonalmente iguais.
- NL** Zorg ervoor dat de bovenste hoeken van de muur diagonaal gelijk zijn.
- CS** Ujistěte se, že horní rohy stěny jsou diagonálně stejné.
- SK** Uistite sa, že horné rohy steny sú diagonálne rovnaké.
- SL** Prepričajte se, da so zgornji vogali stene diagonalno enaki.
- HR** Provjerite jesu li gornji kutovi zida dijagonalno jednaki.
- HU** Ügyeljjen arra, hogy a fal felső sarkai átlósan egyenlőek legyenek.
- SV** Se till att väggens övre hörn är diagonalt lika.
- IT** Assicurati che gli angoli superiori del muro siano diagonalmente uguali.
- PL** Upewnij się, że górne rogi ściany są równe po przekątnej.
- RO** Asigurați-vă că colțurile superioare ale peretelui sunt egale în diagonală.
- BG** Уверете се, че горните ъгли на стената са равни по диагонал.
- TR** Duvarın üst köşelerinin çapraz olarak eşit olduğundan emin olun.



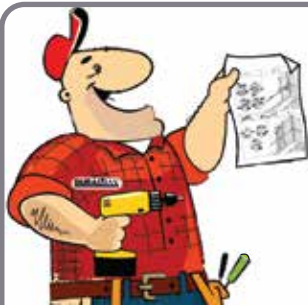

- 4**
- EN Roof Structures
 - CS Střešní konstrukce
 - IT Strutture di tetto
 - FR Structure Du Toit
 - SK Strešné konštrukcie
 - PL Struktura dachu
 - DE Dachkonstruktionen
 - SL Strešne Konstrukcije
 - RO Structuri de acoperiș
 - ES Estructuras de techo
 - HR Krovne konstrukcije
 - BG Покривни конструкции
 - PT Estrutura do Telhado
 - HU Tetőszerkezetek
 - TR Çati yapıları
 - NL Dakconstructies
 - SV Takstrukturer

- EN Parts needed
- CS Potřebné součásti
- IT Parti occorrenti
- FR Pièces nécessaires
- SK Potrebne časti
- PL Niezbędne elementy
- DE Benötigte Teile
- SL Dele, ki jih boste potrebovali
- RO Elementele componente necesare
- ES Piezas necesitadas
- HR Dijelovi potreban
- BG Необходими части
- PT Peças Necessárias
- HU Szükséges részek
- TR Gereklı parçalar
- NL Onderdelen nodig
- SV Delar som behövs

E	1	FDCL	1
F	1	FDCR	1
VRC05	2	FCC	4
VRC06	1	S1	52
VRC07	2	S2	4
VRC08	2	S7	8
VRC09	2	SJ1	10
VRC10	4		

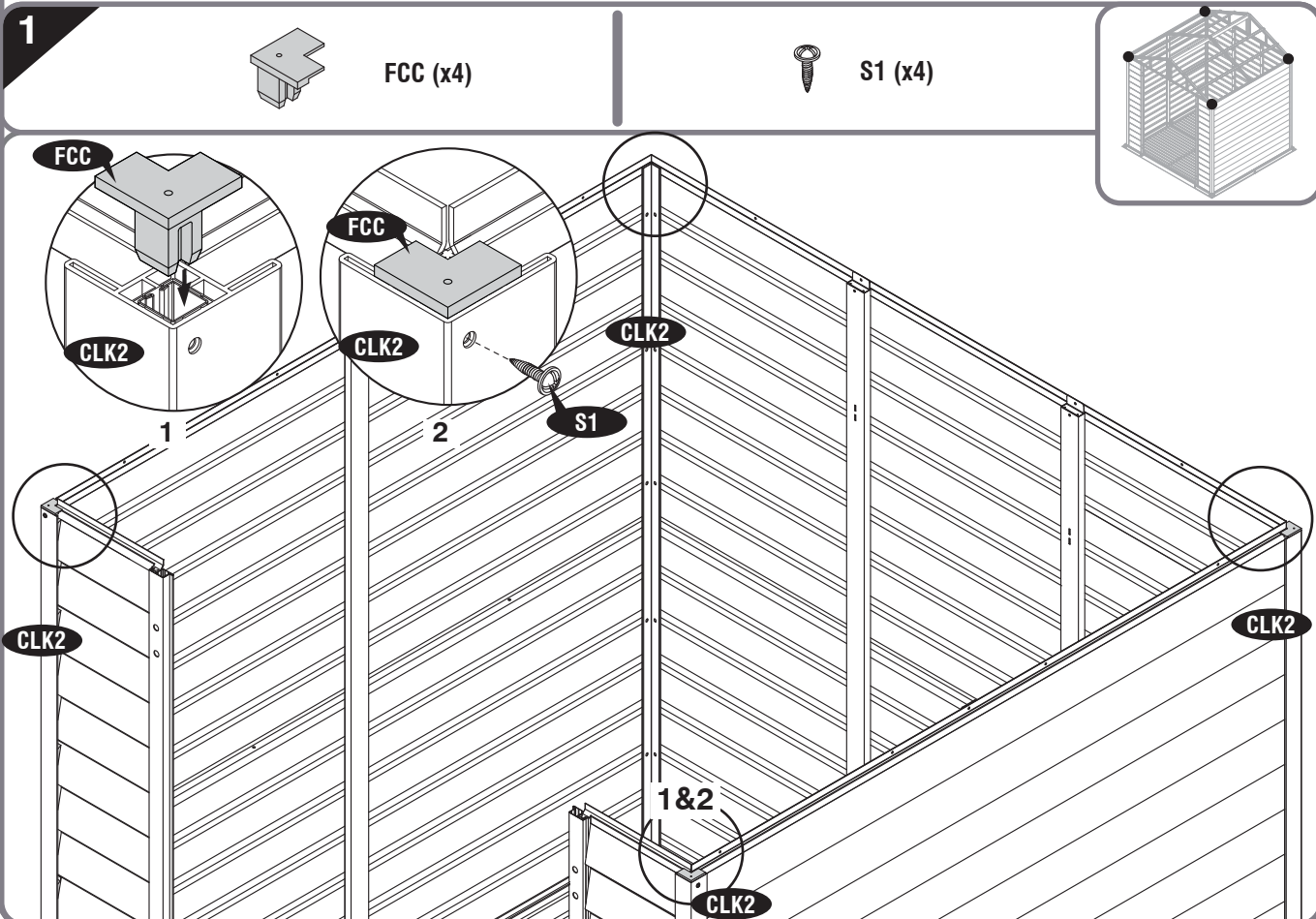

2

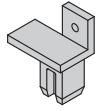

FDCL (x1)

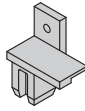

FDCR (x1)



S1 (x2)

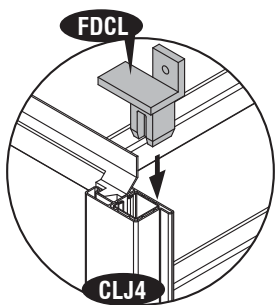
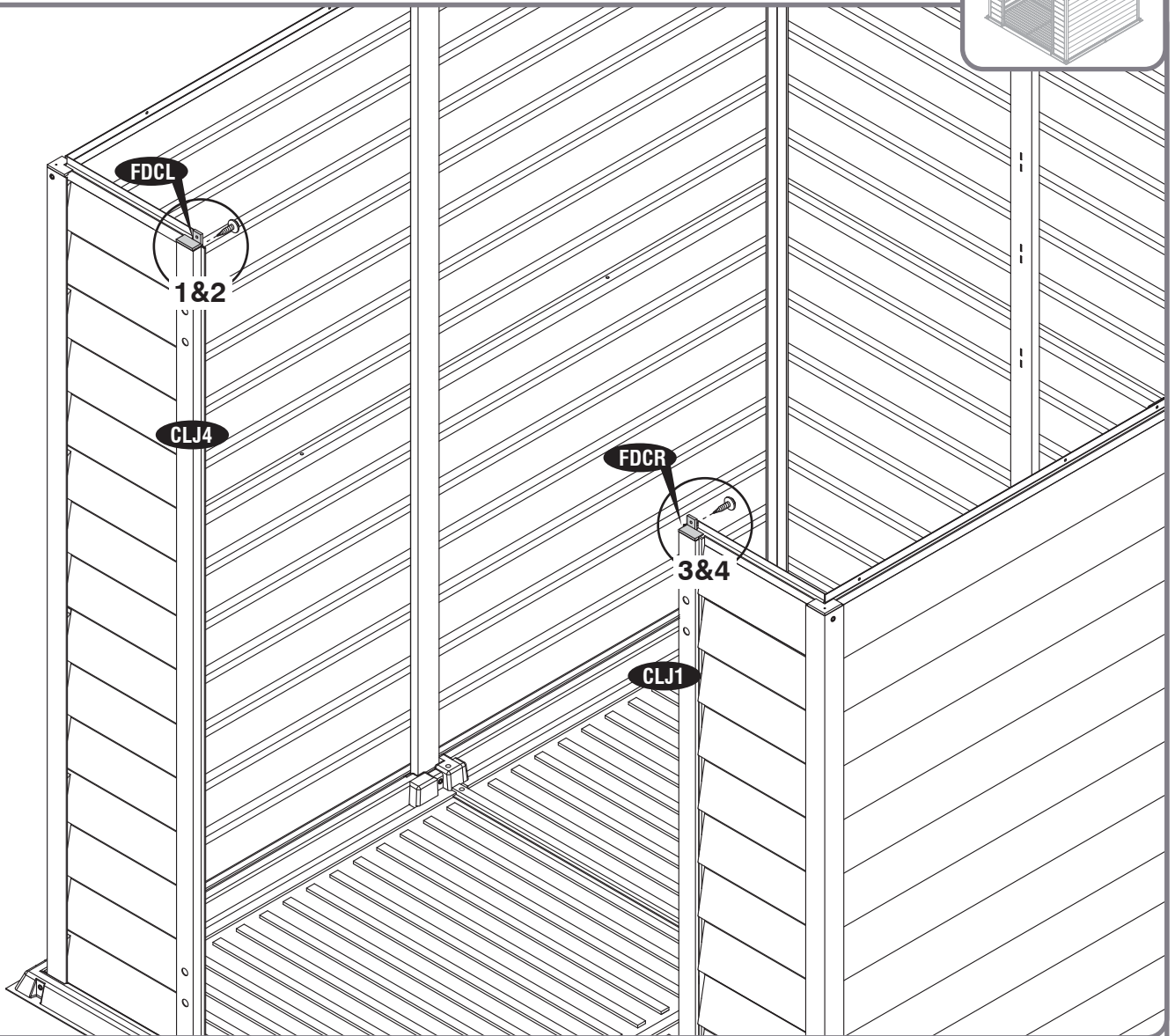
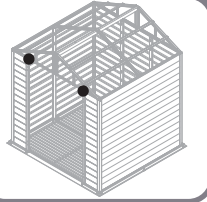

1

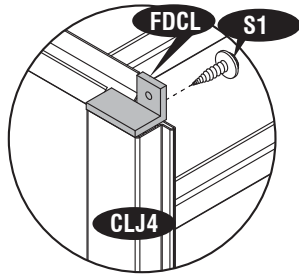

2

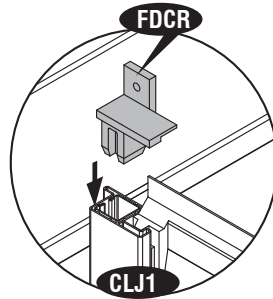

3

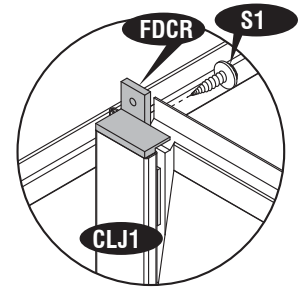

4

- | | | | |
|----|--------------------------------------|----|---------------------------------|
| EN | Roof Structure Assembly | HR | Sklop krovne konstrukcije |
| FR | Assemblage De La Structure Du Toit | HU | Tetőszerkezet szerelvény |
| DE | Dachkonstruktion Montage | SV | Takkonstruktion |
| ES | Montaje de la estructura de techo | IT | Assemblea tetto della struttura |
| PT | Armação da Estrutura do Telhado | PL | Montaż konstrukcji dachu |
| NL | Dakconstructie montage kit | RO | Coinneamh Structar Deil |
| CS | Montážní souprava střešní konstrukce | BG | Покривна конструкция събрание |
| SK | Montáž konštrukcie strechy | TR | Çatı Yapısı Meclisi |
| SL | Sestavni Deli Strešne Konstrukcije | | |

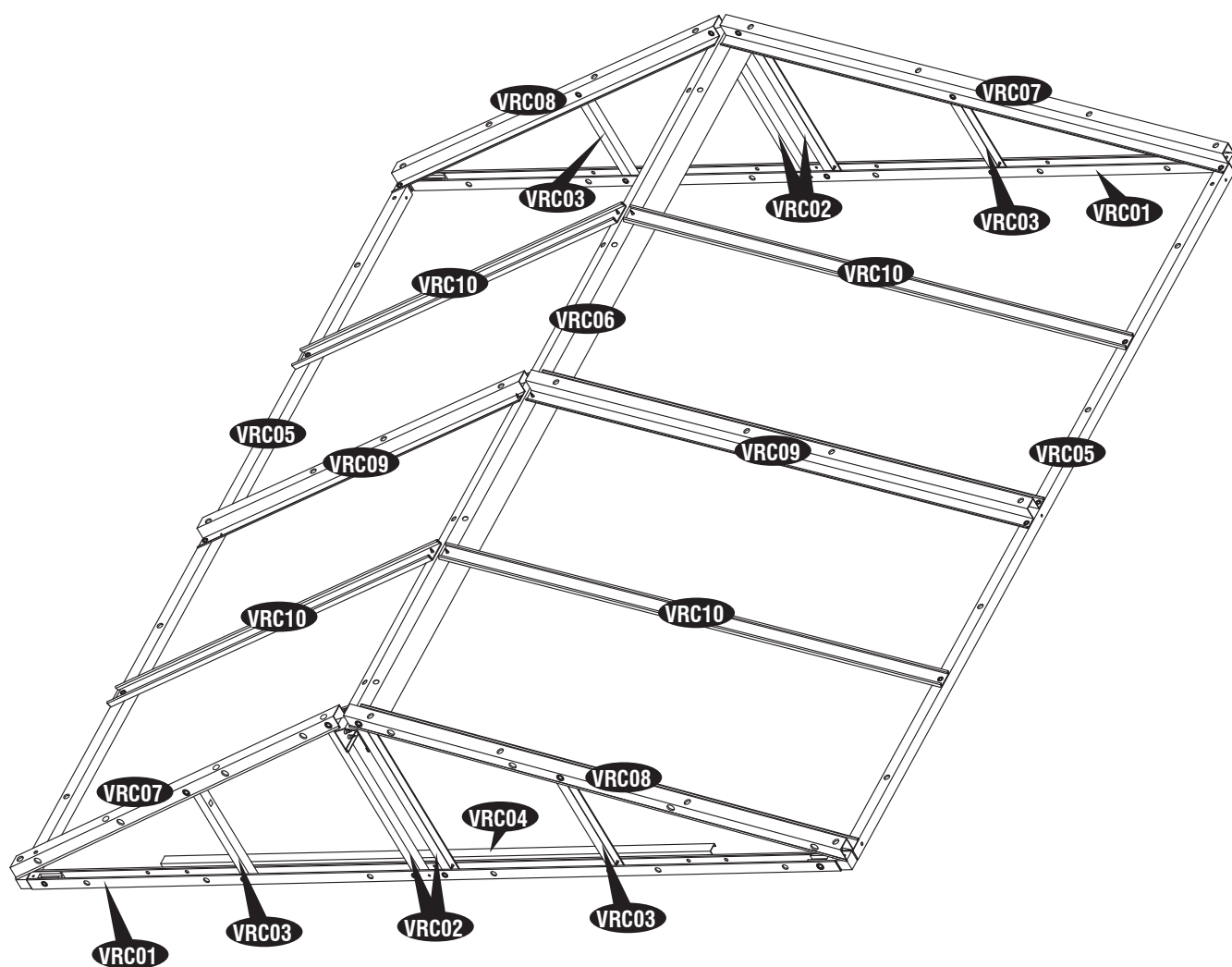

3

E (x1)

S1 (x2)

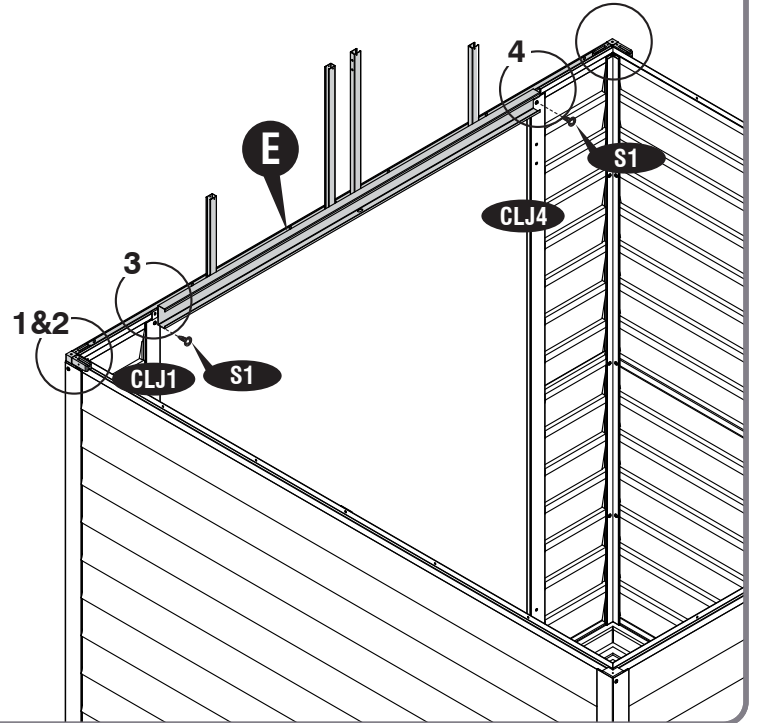
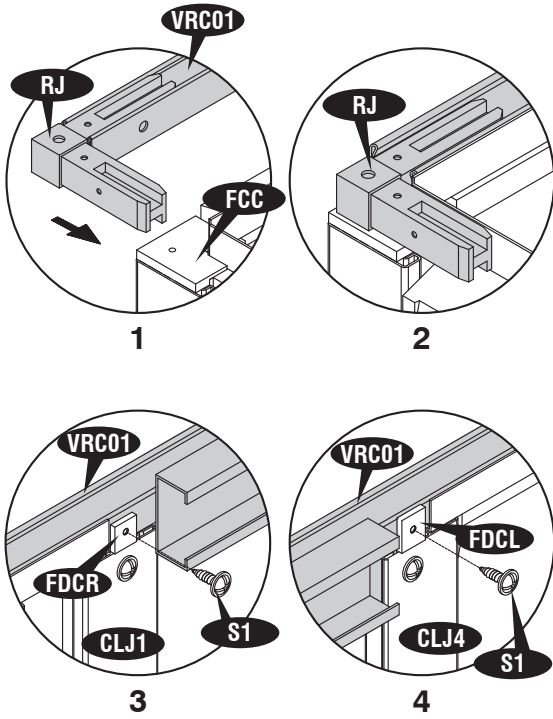
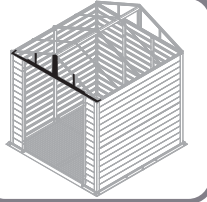

4

S2 (x2)

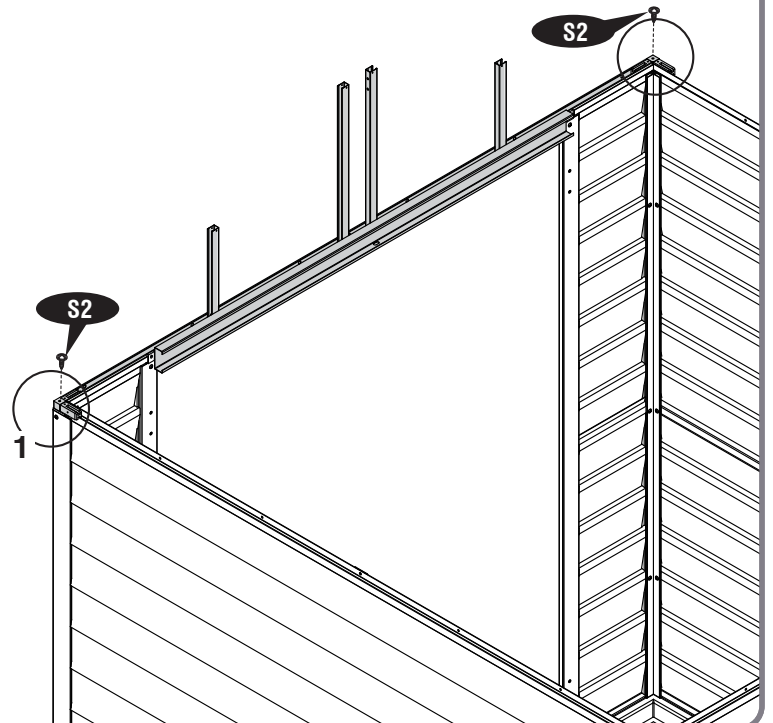
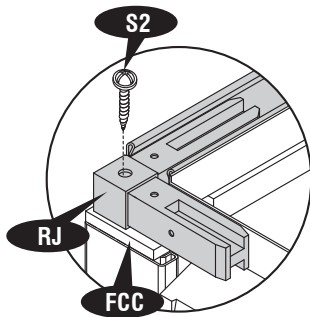
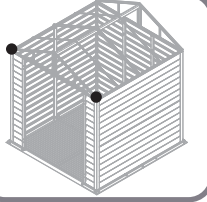

5

F (x1)

S1 (x2)

S2 (x2)

SJ1 (x2)

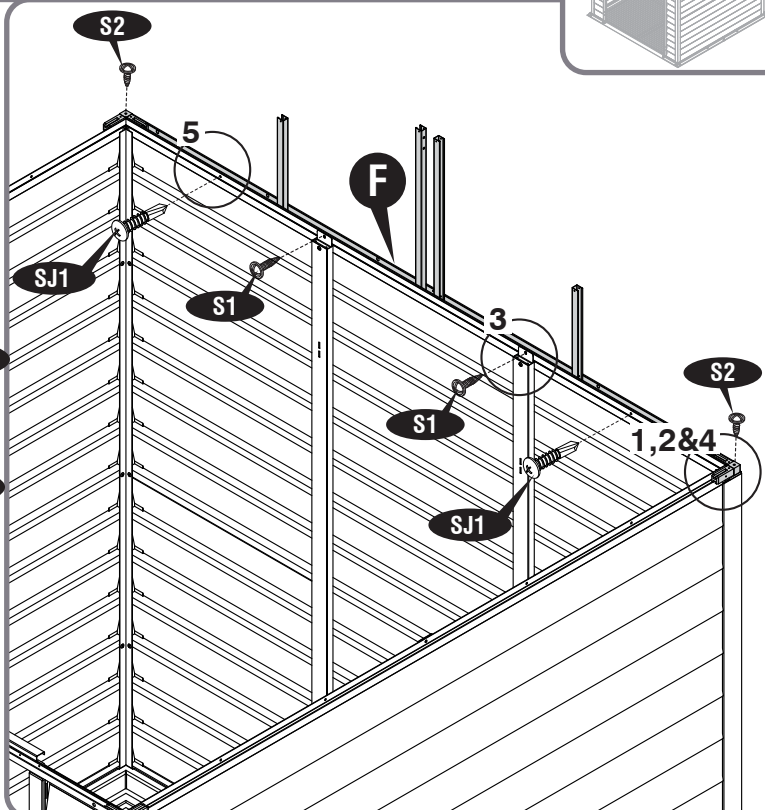
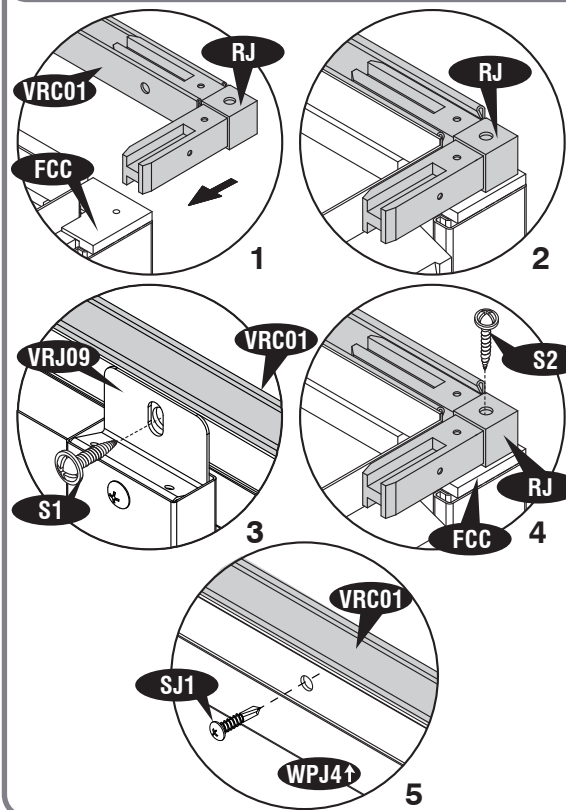
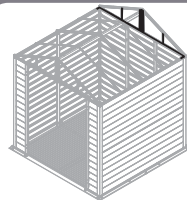

6

VRC05 (x2)

S1 (x6)

SJ1 (x8)

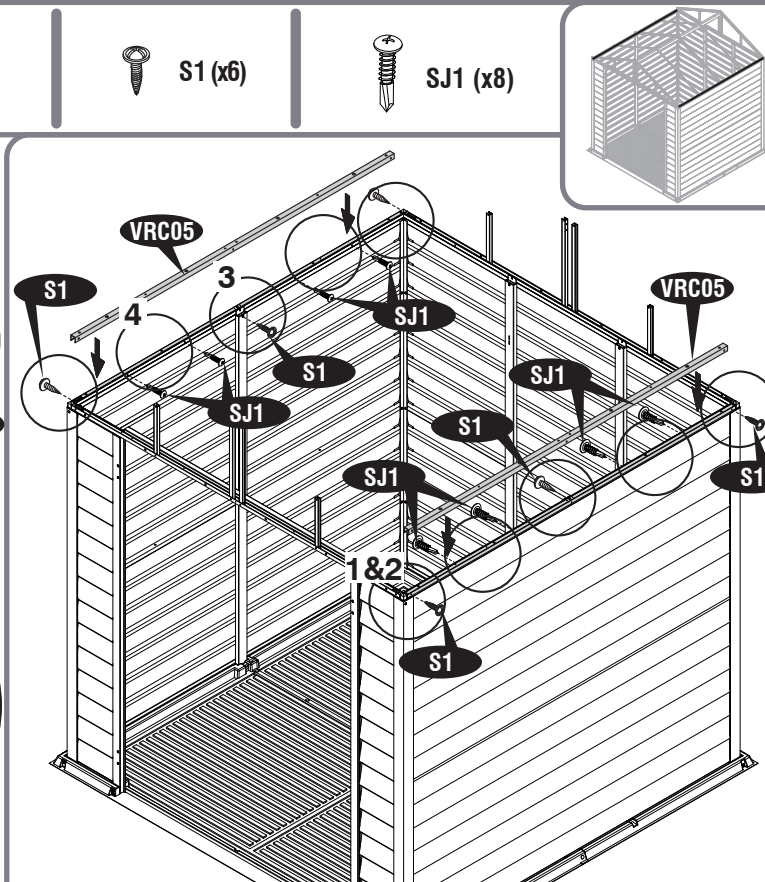
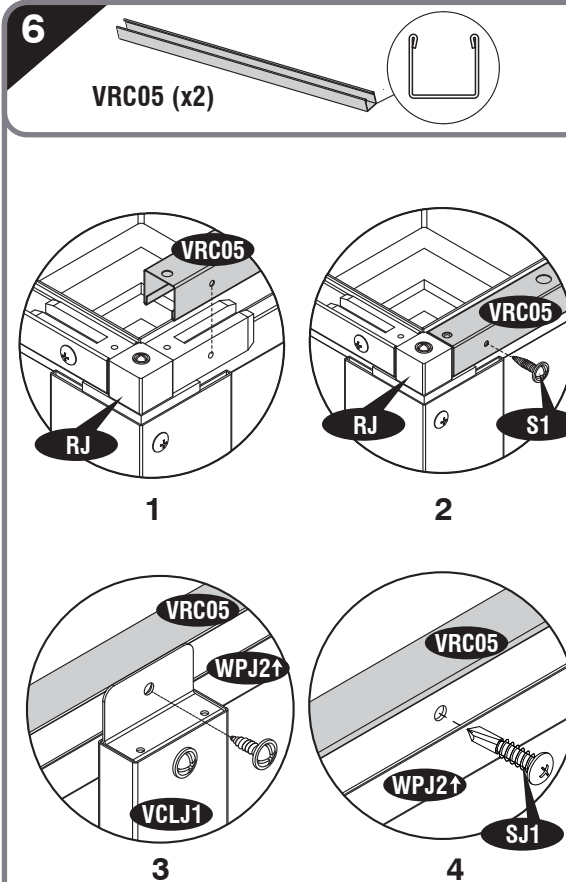
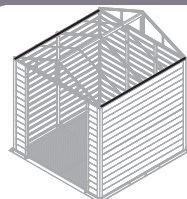

7

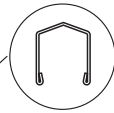
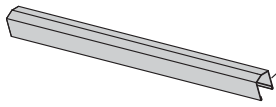

VRC06 (x1)



S1 (x8)

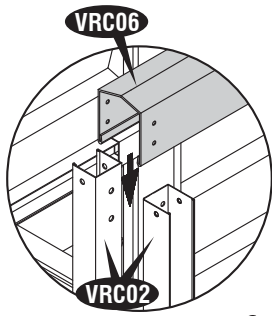
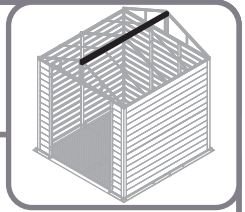

1

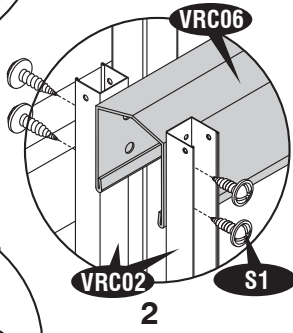

2

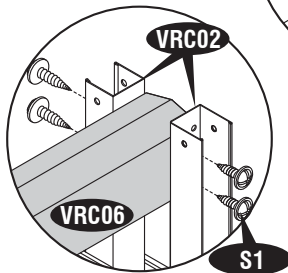

3

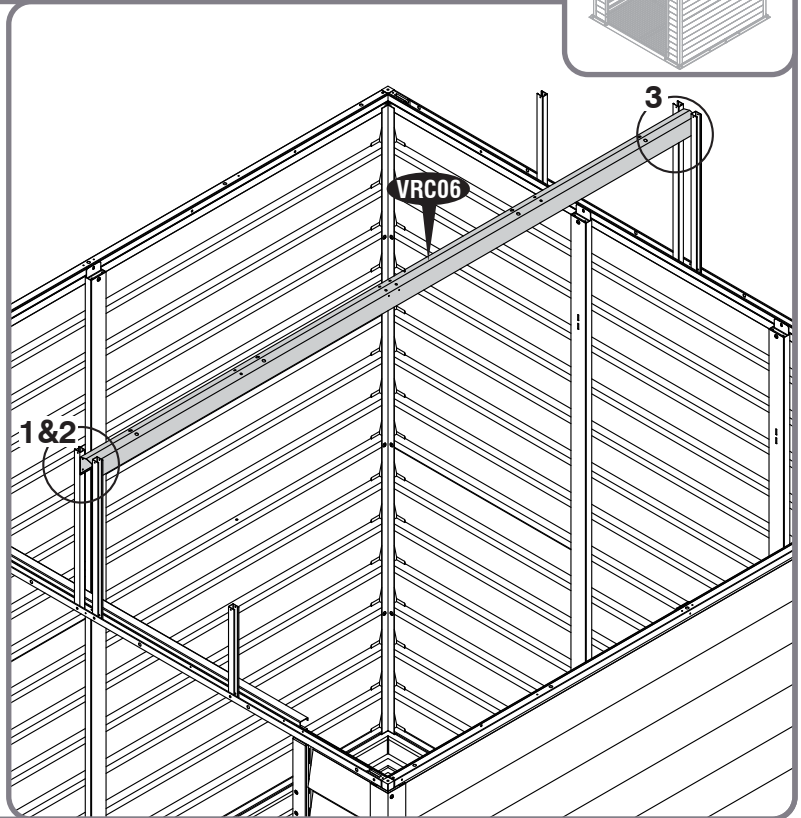

8



VRC07 (x2)
VRC08 (x2)



S1 (x20)

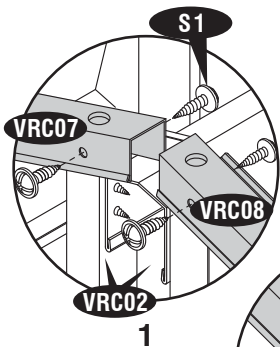
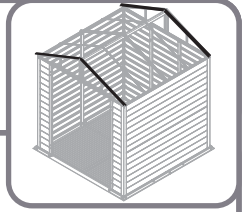

1

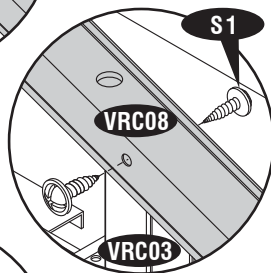

2

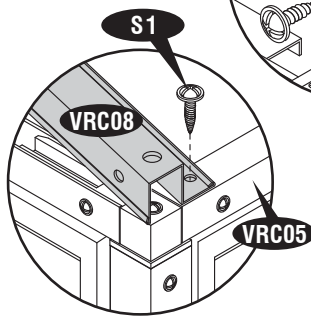

3

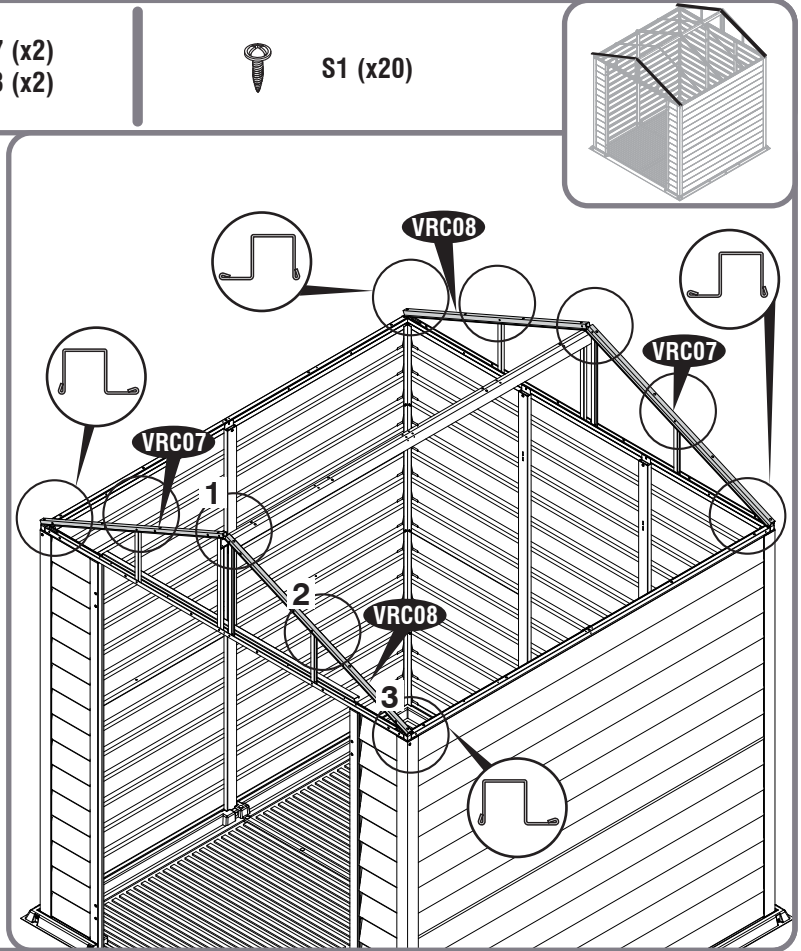

9



VRC09 (x2)



S1 (x4)

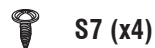

S7 (x4)

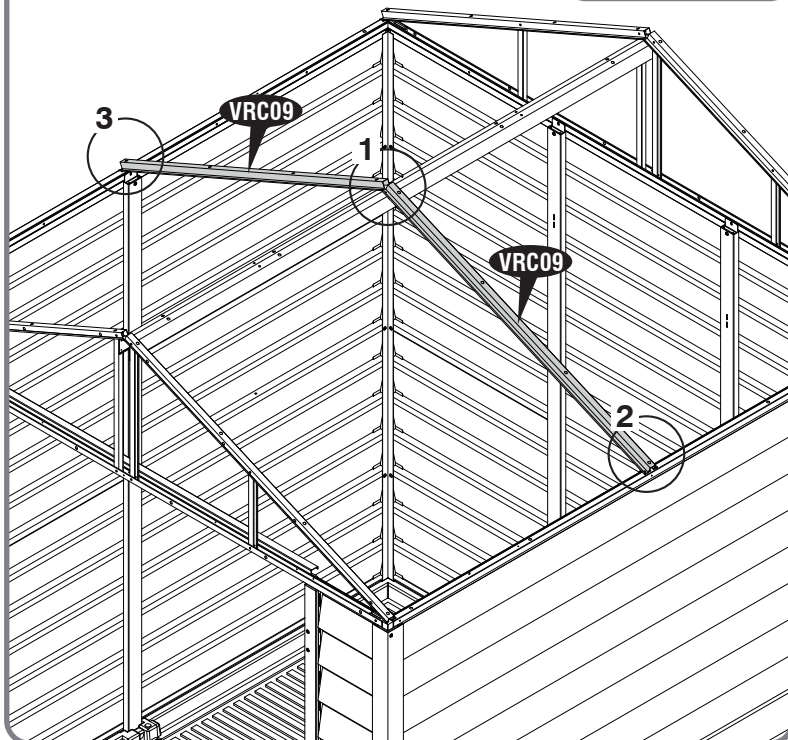
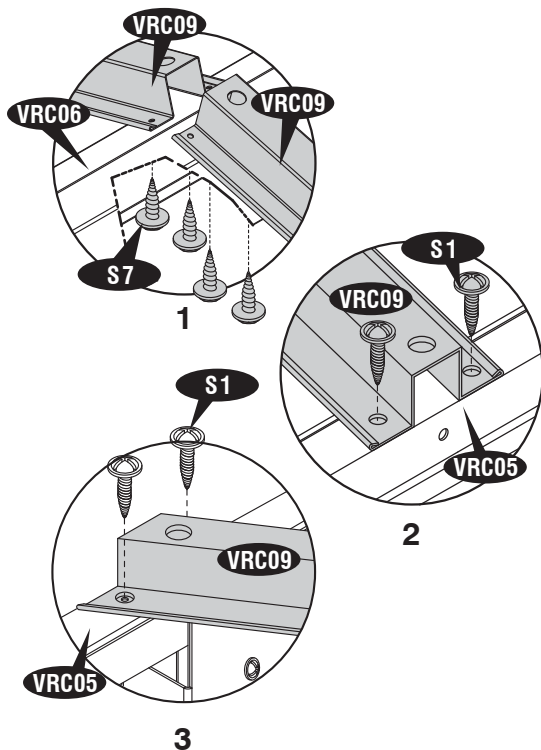
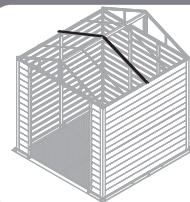

10

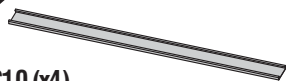

VRC10 (x4)



S7 (x4)



S1 (x4)

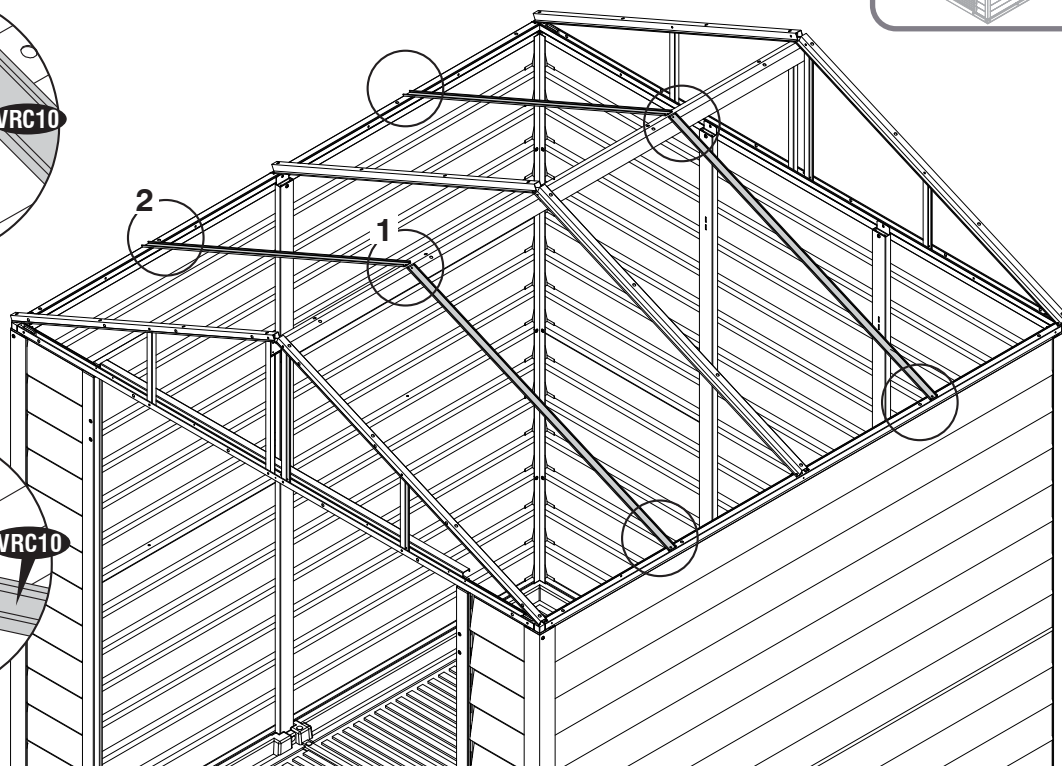
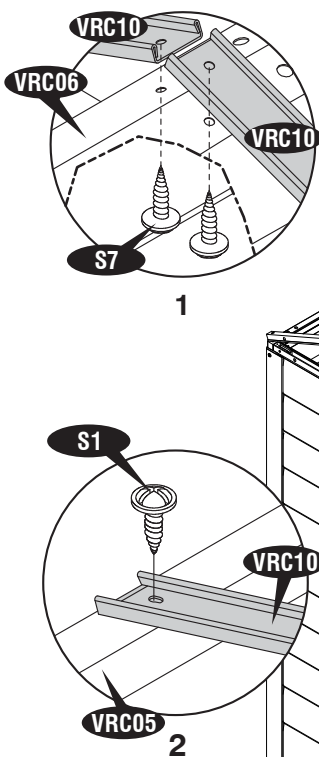
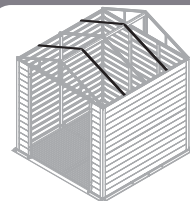

- EN** Make sure that both diagonal distances are equal.
- FR** Assurez-vous que les deux distances diagonales sont égales.
- DE** Achten Sie darauf, dass beide Diagonalabstände gleich sind.
- ES** Asegúrese de que ambas distancias diagonales sean iguales.
- PT** Certifique-se de que ambas as distâncias diagonais sejam iguais.
- NL** Zorg ervoor dat beide diagonale afstanden gelijk zijn.
- CS** Ujistěte se, že obě diagonální vzdálenosti jsou stejné.
- SK** Uistite sa, že obe diagonálne vzdialenosti sú rovnaké.
- SL** Prepričajte se, da sta obe diagonalni razdalji enaki.
- HR** Uvjerite se da su obje dijagonalne udaljenosti jednake.
- HU** Győződjön meg arról, hogy mindkét átló távolsága egyenlő.
- SV** Se till att båda diagonala avstånden är lika.
- IT** Assicurati che entrambe le distanze diagonali siano uguali.
- PL** Upewnij się, że obie przekątne odległości są równe.
- RO** Asigurați-vă că ambele distanțe diagonale sunt egale.
- BG** Уверете се, че двата диагонални разстояния са равни.
- TR** Her iki çapraz mesafenin eşit olduğundan emin olun.

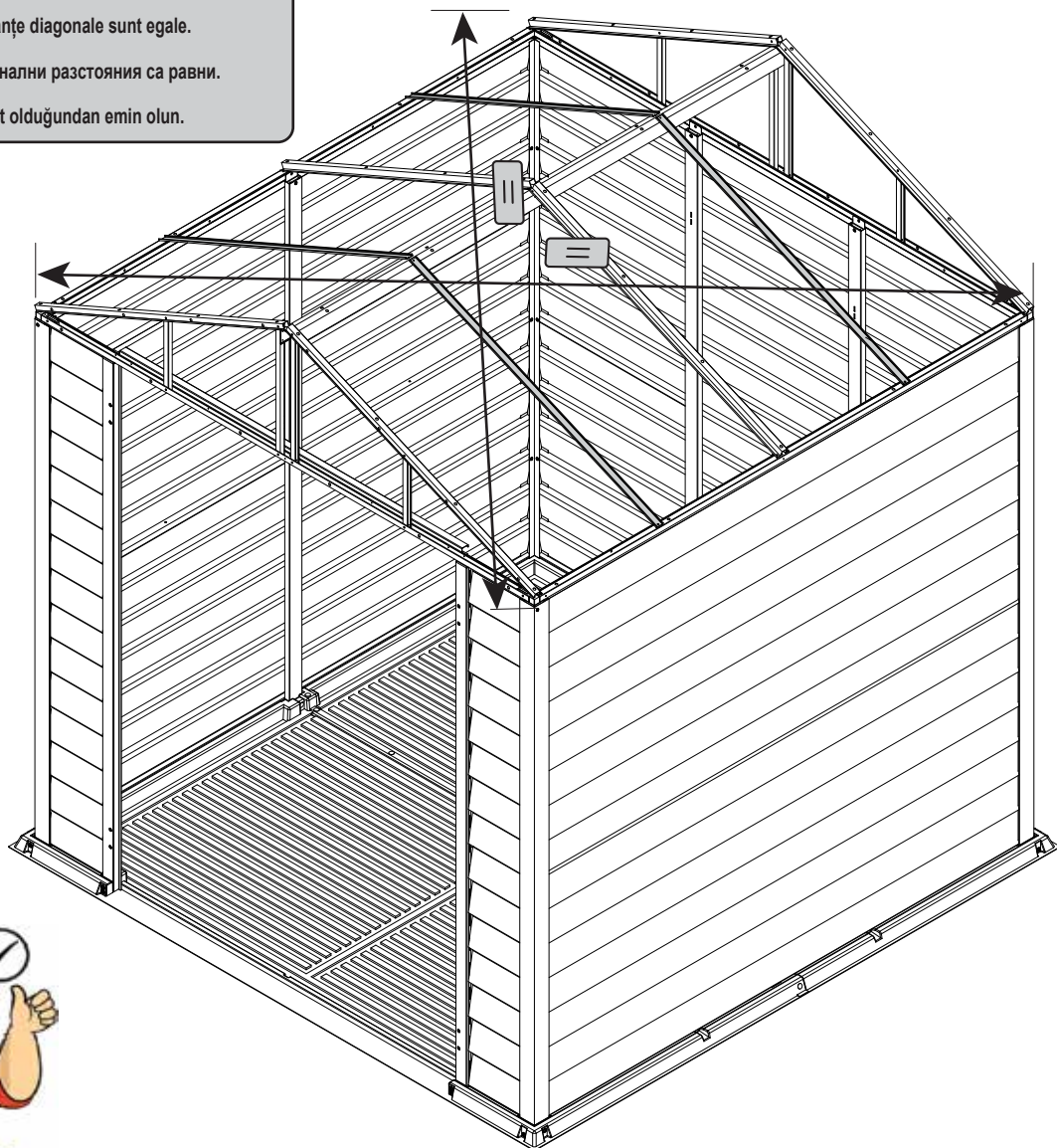

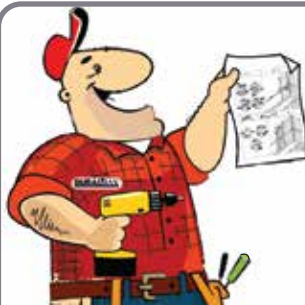

5

- | | | |
|------------------------|-------------------|------------------------|
| EN Roof Panels | CS Střešní panely | IT Pannelli del tetto |
| FR Planches de Toiture | SK Strešné panely | PL Panele dachowe |
| DE Dachplatten | SL Strešni Paneli | RO Panouri de acoperiș |
| ES Paneles de techo | HR Krovne ploče | BG Покривни панели |
| PT Painéis do Telhado | HU Tetőpanelék | TR Çatı Panelleri |
| NL Dakpanelen | SV Takpaneler | |

- | | | |
|-----------------------|-----------------------------------|-----------------------------------|
| EN Parts needed | CS Potřebné součásti | IT Parti occorrenti |
| FR Pièces nécessaires | SK Potrebne časti | PL Niezbędne elementy |
| DE Benötigte Teile | SL Dele, ki jih boste potrebovali | RO Elementele componente necesare |
| ES Piezas necesitadas | HR Dijelovi potreban | BG Необходими части |
| PT Peças Necessárias | HU Szükséges részek | TR Gerekli parçalar |
| NL Onderdelen nodig | SV Delar som behövs | |



FPC	2	BP	28
RPC1†	2	FP	4
RPC2†	1	PPG	40
EC2	2	PIN	40

- EN Use Same color Plugs(BP).
- FR Utilisez les bouchons de même couleur (BP).
- DE Verwenden Sie die gleichen Farbstopfen (BP).
- ES Utilice tapones del mismo color (BP).
- PT Use os plugues da mesma cor (BP).
- NL Gebruik pluggen in dezelfde kleur (BP).
- CS Použijte zástrčky stejné barvy (BP).
- SK Použite zástrčky rovnakej farby (BP).
- SL Uporabite iste barvne vtiče (BP).
- HR Upotrijebite utikače iste boje (BP).
- HU Használjon azonos színű dugókat (BP).
- SV Använd samma färgpluggar (BP).
- IT Utilizzare spine dello stesso colore (BP).
- PL Użyj wtyczek tego samego koloru (BP).
- RO Folosiți fișe de aceeași culoare (BP).
- BG Използвайте едни и същи цветни щепсели (BP).
- TR Aynı renkteki Fişleri (BP) kullanın.

1

FPC (x1)

BP (x14)

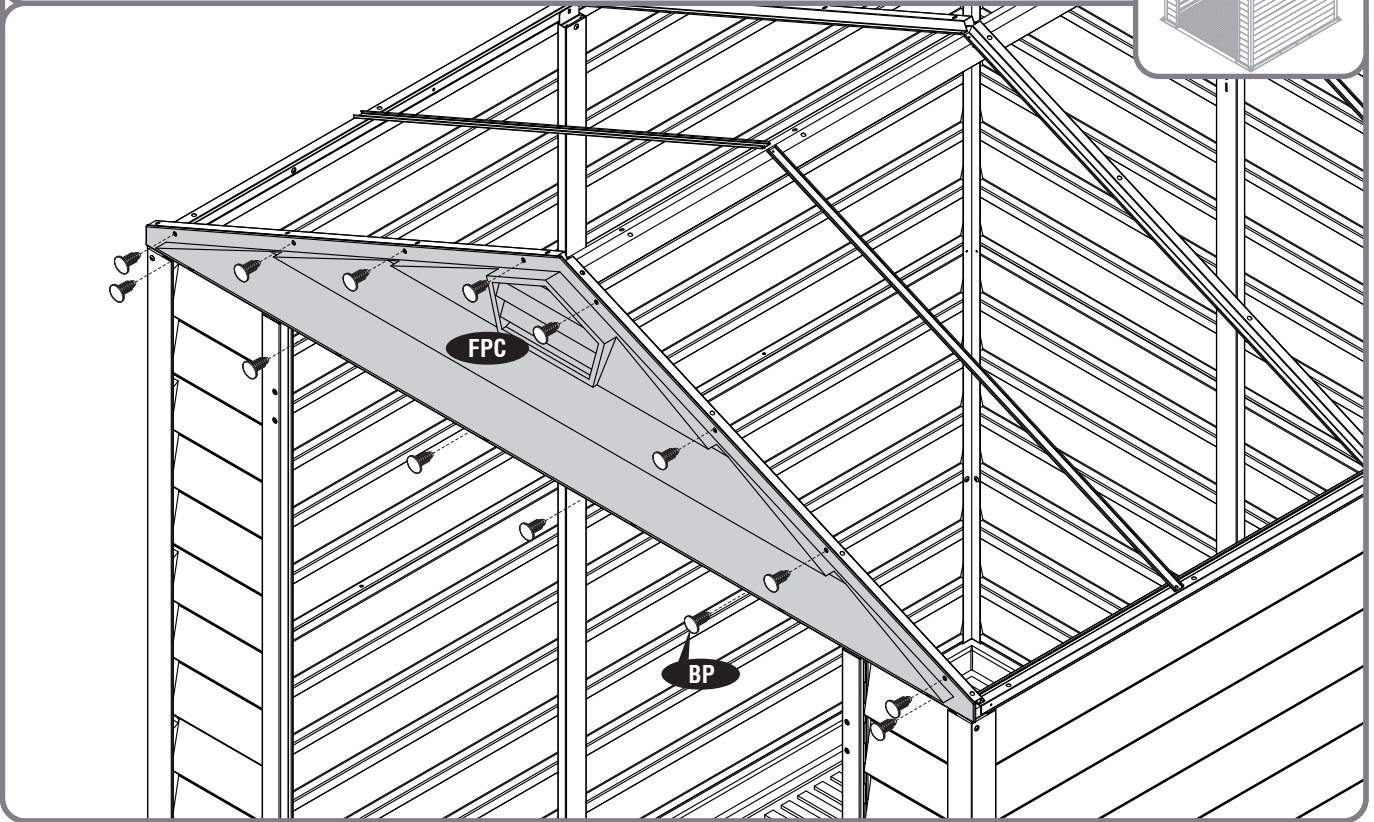
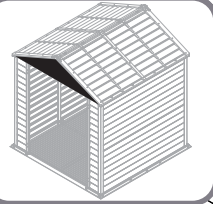

2

FPC (x1)

BP (x14)

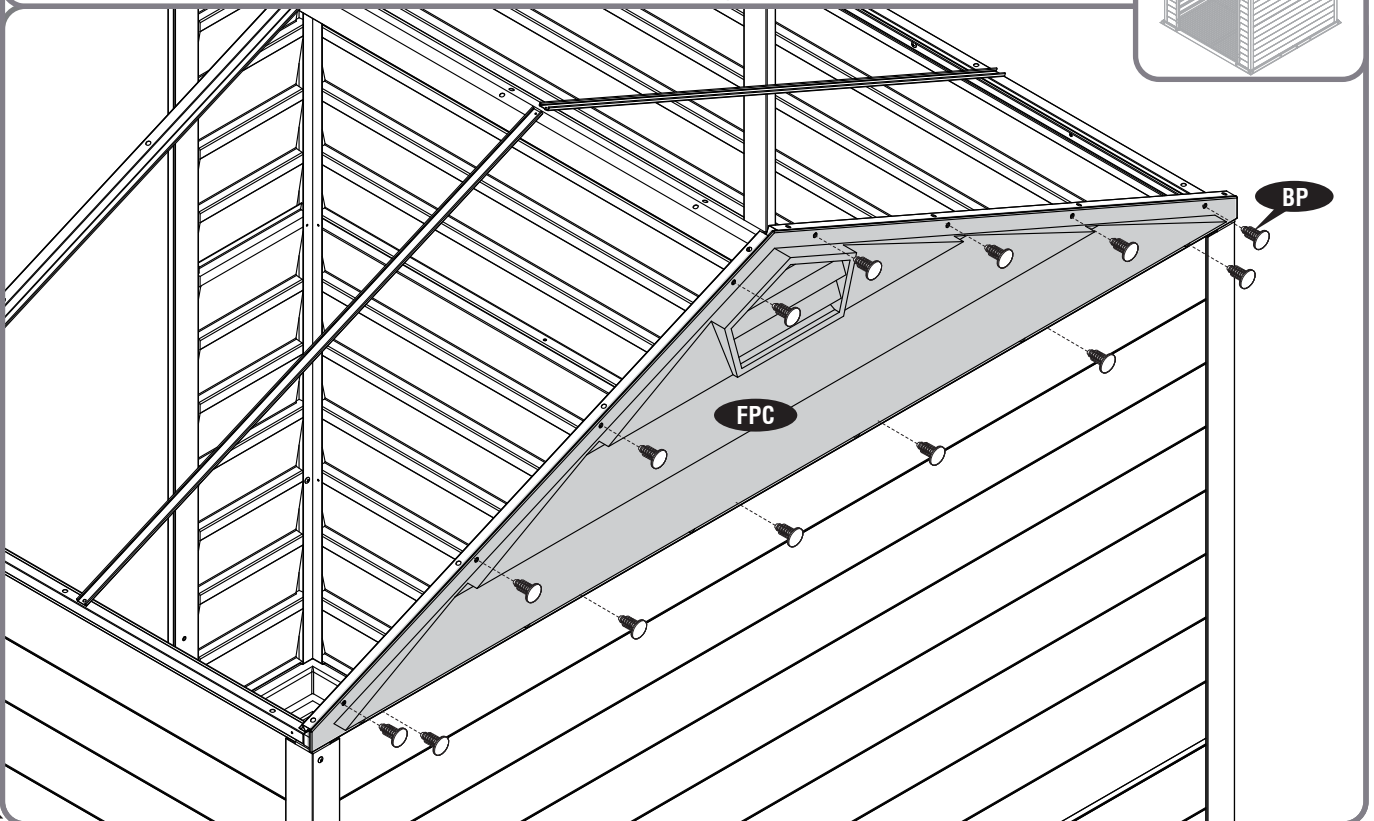
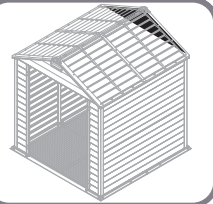



- EN Apply silicone into the holes before inserting the pins (Silicone not included).
- FR Appliquez de la silicone dans les trous avant d'insérer les broches (silikon nicht enthalten).
- DE Anwenden Silikon in die Löcher vor dem Einsetzen der Stifte (Silikon nicht enthalten).
- ES Aplicar silicona en los agujeros antes de insertar los pasadores (Silicona no incluido).
- PT Aplique silicone nos orifícios antes de inserir os pinos (Silicone não incluído).
- NL Breng siliconen aan in de gaten voordat u de pinnen inbrengt (siliconen niet inbegrepen).
- CS Použijte silikon do otvorů před vložením kolíků (silikon není součástí dodávky).
- SK Silikón naneste do otvorov pred vložením kolíkov (silikón nie je súčasťou dodávky).
- SL Vstavite silikon v luknje, preden vstavite zatič (silikon ni priložen).
- HR Nanesite silikon u rupe prije umetanja igle (Silikonski dio nije uključen).
- HU A tük behelyezése előtt szilikonot kell behelyezni a lyukba (a szilikon nem tartozék).
- SV Applicera silikon i hålen innan du sätter in stiften (Silikon ingår inte).
- IT Applicare il silicone nei fori prima di inserire i perni (non in silicone).
- PL Stosuje się silikon w otwory przed włożeniem szpilki (nie zawiera silikonu).
- RO Aplicați siliconul în orificii înainte de a introduce știfturile (siliconul nu este inclus).
- BG Нанесете силикон в дупките преди да поставите щифтовете (силикон не са включени).
- TR Pimler yerleştirmeden önce deliğe silikon uygulayın (Silikon dahil değildir).

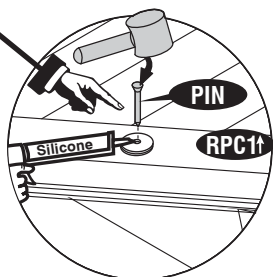
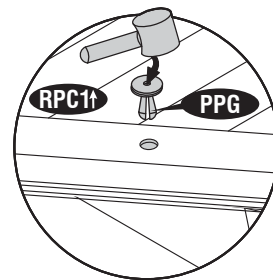

- EN Use a screwdriver to align the holes.
Insert roof plugs into roof panels only as indicated.
- FR Utilisez un tournevis pour aligner les trous.
Inserez les chevilles de plastique dans les panneaux de toiture uniquement, comme indiqué.
- DE Richten Sie die Löcher mit einem Schraubendreher aus.
Setzen Sie die Dachstopfen nur wie angegeben in die Dachverkleidungen ein.
- ES Utilizar un destornillador para alinear los agujeros.
Inserte tapones de techo en paneles del techo sólo como se indica.
- PT Use uma chave de fenda para alinhar os orifícios.
Insira os bujões do telhado nos painéis do telhado apenas como indicado.
- NL Gebruik een schroevendraaier om de gaten uit te lijnen.
Plaats dakdoppen alleen in dakpanelen zoals aangegeven.
- CS Vyrovnajte otvory pomocí šroubováku.
Střešní zátky zasuňte do střešních panelů pouze tak, jak je uvedeno.
- SK Pomocou skrutkovača zarovnajete otvory.
Strešné zátky zasuňte do strešných panelov len tak, ako je uvedený.
- SL Z izvijačem poravnajte luknje.
Vstavite strešne vtiče v strešne plošče samo, kot je navedeno.
- HR Pomoću odvijača poravnajte rupe.
Umetnite krovne čepove u krovne ploče samo kako je naznačeno.
- HU Használja a csavarhúzóval a lyukakat.
A tetőcsatlakozót csak a jelzett módon tegye a tetőpanelekre.
- SV Använd en skruvmejsel för att anpassa hålen.
Sätt in takpluggarna endast i takpaneler enligt anvisningarna.
- IT Utilizzare un cacciavite per allineare i fori.
Inserire i tappi del tetto nei pannelli del tetto solo come indicato.
- PL Użyj śrubokręta, aby wyrównać otwory.
Włóżć kołki dachowe do paneli dachowych tylko tak, jak wskazano.
- RO Folosiți o șurubelniță pentru alinierea găurilor.
Introduceți dopurile de acoperiș în panourile de acoperiș numai așa cum este indicat.
- BG Използвайте отвертка, за да подравните отворите.
Поставете покривните тапи в покривните панели само както е посочено.
- TR Delikleri hizalamak için bir tornavida kullanın.
Tavan tapalarını sadece belirtildiği gibi tavan panellerine yerleştirin.

3

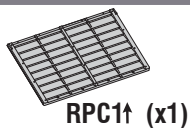

RPC1↑ (x1)



PPG (x13)



PIN (x13)

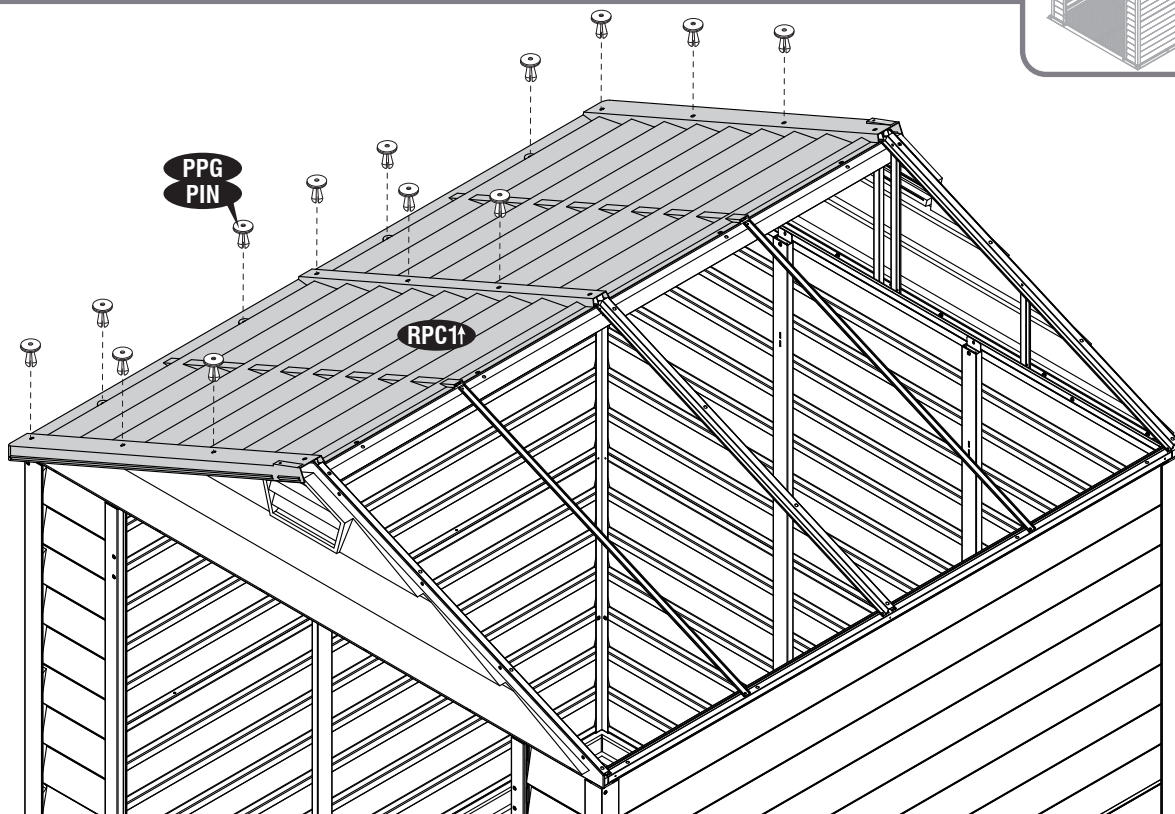
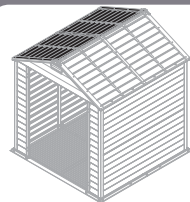

EN Apply silicone around the roof plugs.(Silicone not included).

FR Appliquez du silicone autour des bouchons de toit. (Silicone non inclus).

DE Tragen Sie Silikon um die Dachstopfen auf (Silikon nicht im Lieferumfang enthalten).

ES Aplique silicona alrededor de los tapones del techo (silicona no incluida).

PT Aplique silicone ao redor das tampas do telhado (Silicone não incluído).

NL Breng siliconen aan rond de dakpluggen. (Siliconen niet inbegrepen).

CS Okolo střešních zátek naneste silikon (silikon není součástí balení).

SK Silikón naneste na strešné zátky (silikón nie je súčasťou dodávky).

SL Okoli strešne čepe nanesite silikon (Silikon ni priložen).

HR Nanesite silikon oko krovnih čepova. (Silikon nije uključen).

HU Vigyen fel szilikonot a tetőcsavarok körül (a szilikon nem tartozék).

SV Applicera silikon runt takpropparna (silikon ingår inte).

IT Applicare silicone attorno ai tappi del tetto (silicone non incluso).

PL Nałóż silikon wokół kołków dachowych (nie zawiera silikonu).

RO Aplicați silicon în jurul dopurilor de acoperiș. (Silicon nu este inclus).

BG Нанесете силикон около тапите на покрива. (Силиконът не е включен).

TR Tavan tapalarının çevresine silikon uygulayın (Silikon dahil değildir).

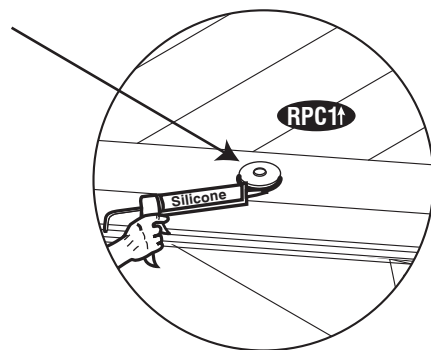

5

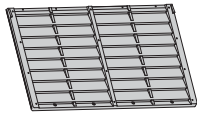

RPC1t (x1)

PPG (x13)

PIN (x13)

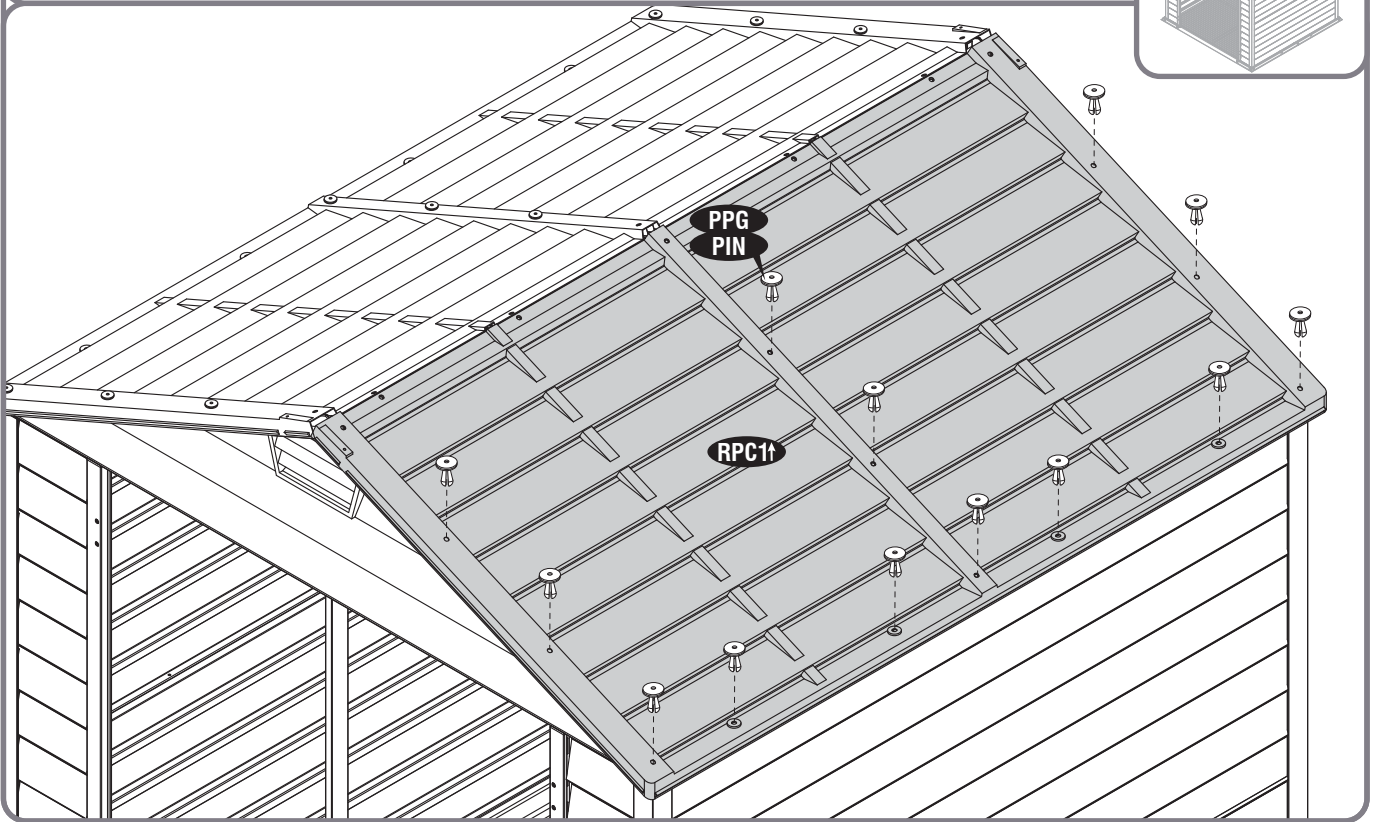
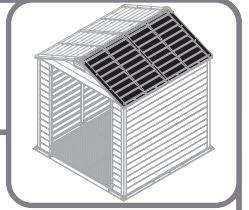

6



RPC2 (x1)

PPG (x14)

PIN (x14)

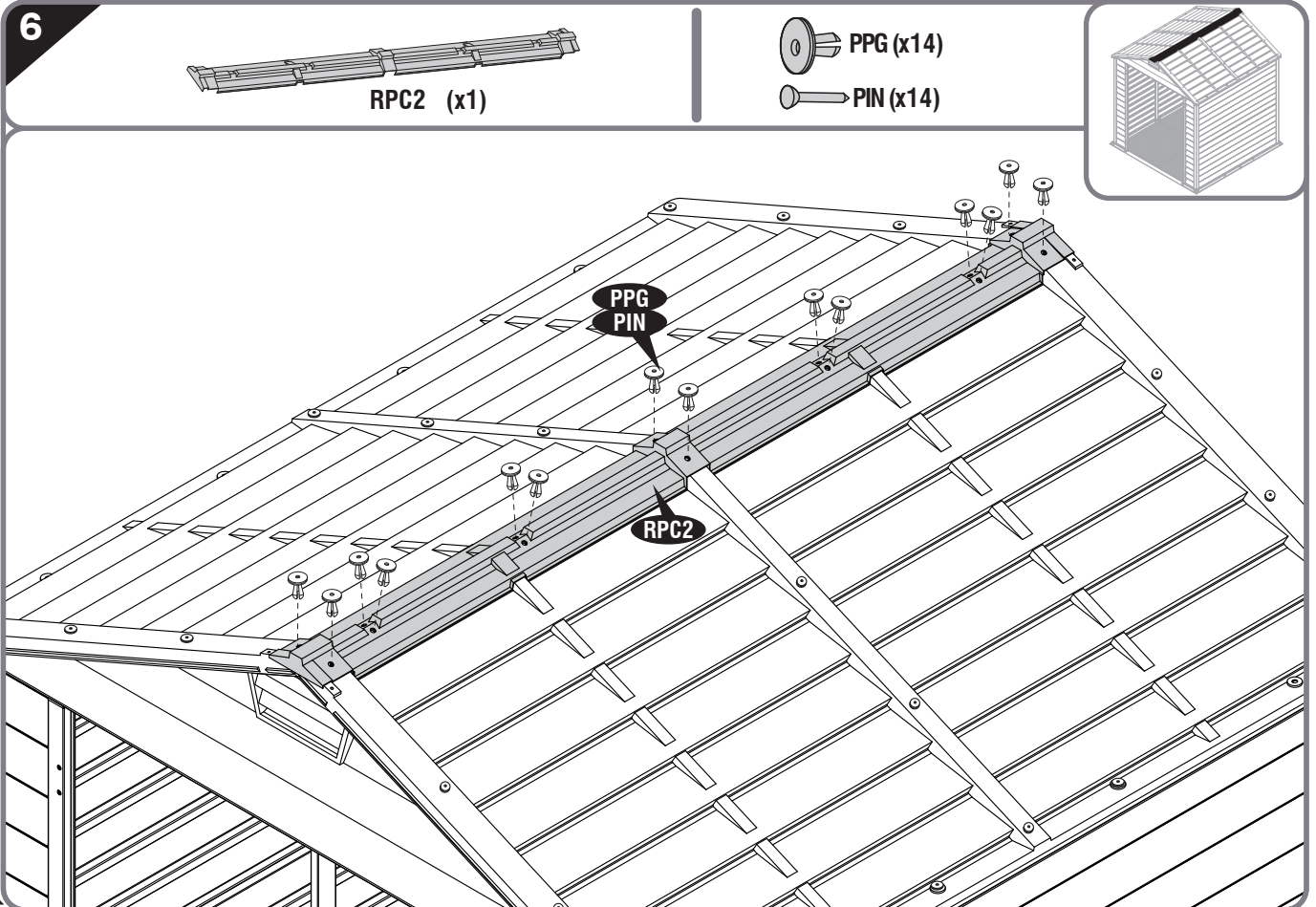
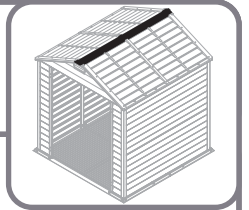

7

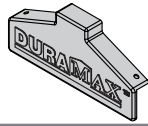

EC2 (x2)



FP (x4)

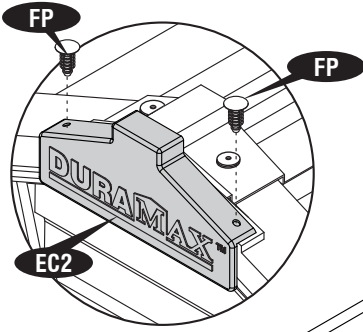
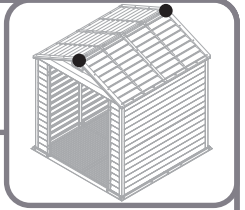

FP

FP

EC2

EC2

EC2

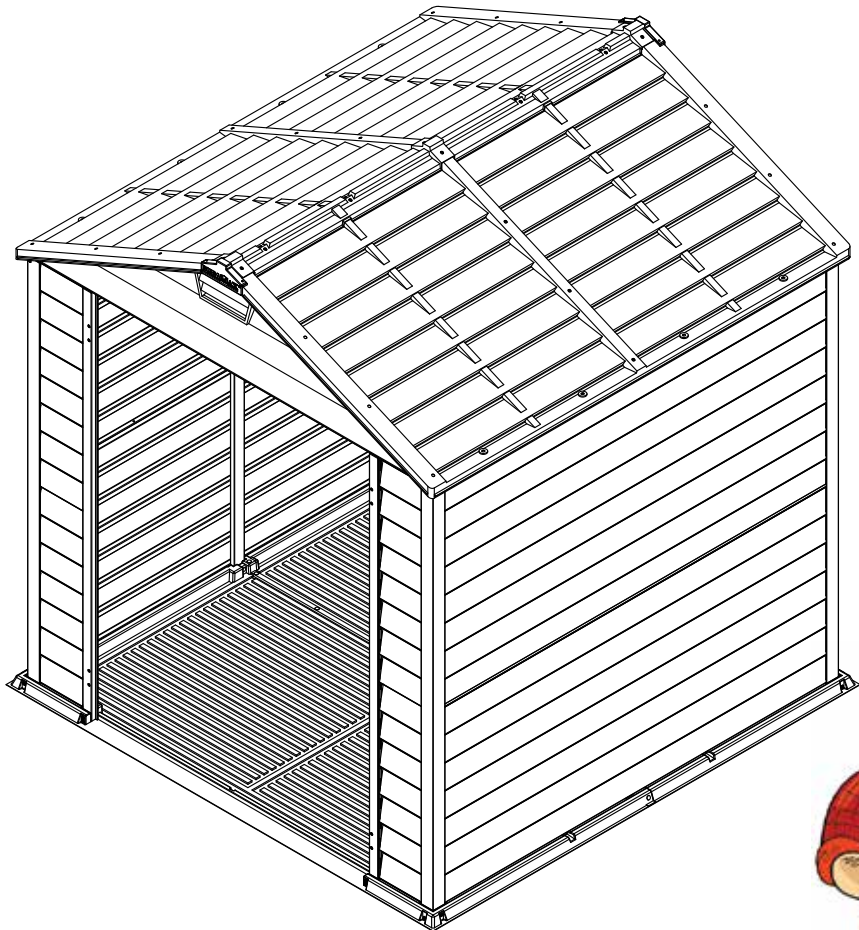
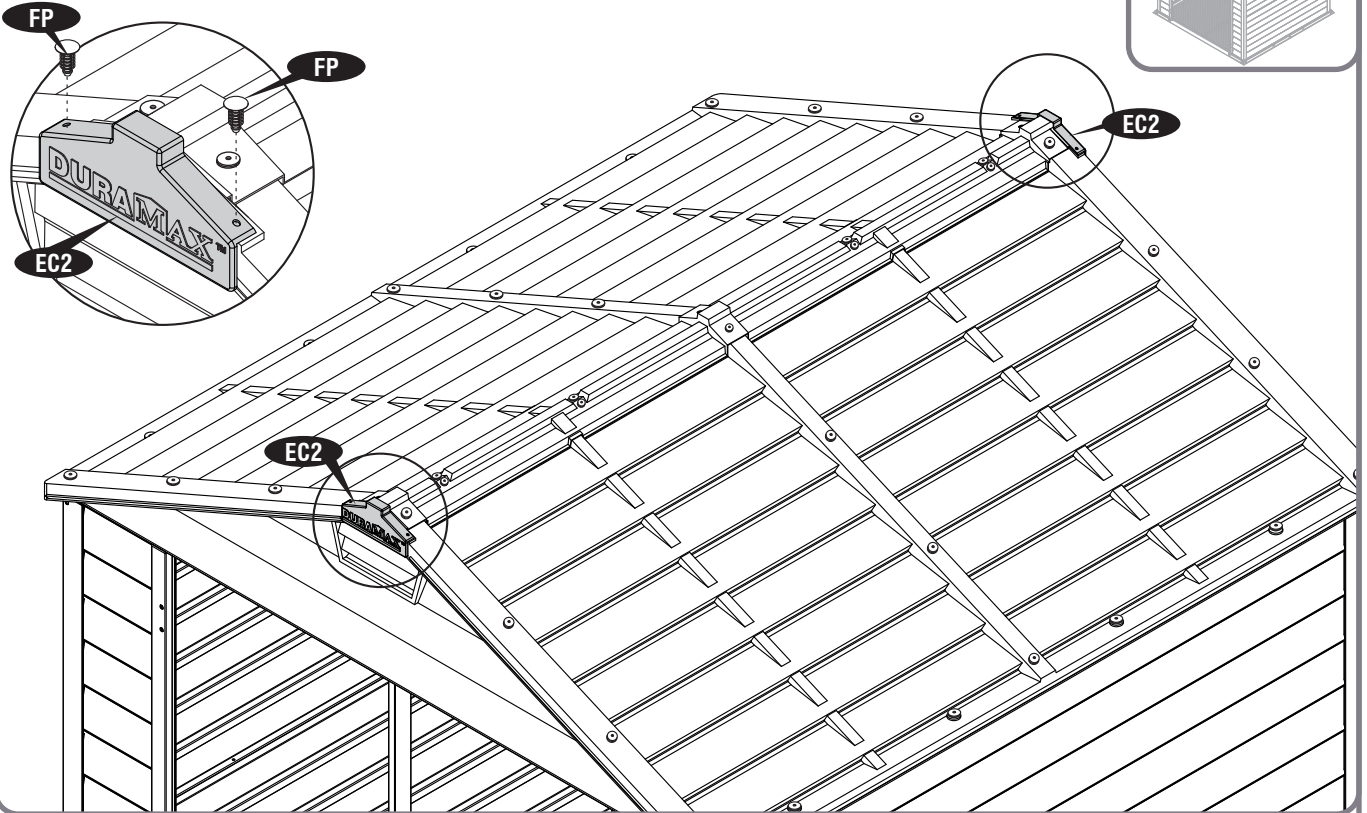



6

- | | | |
|--------------|----------|----------|
| EN Door | CS Dveře | IT Porta |
| FR Porte | SK Dvere | PL Drzwi |
| DE Die Tür | SL Vrata | RO Ușa |
| ES La puerta | HR Vrata | BG Врата |
| PT Porta | HU Ajtó | TR Kapı |
| NL De deur | SV Dörr | |

- | | | |
|-----------------------|-----------------------------------|-----------------------------------|
| EN Parts needed | CS Potřebné součásti | IT Parti occorrenti |
| FR Pièces nécessaires | SK Potřebné části | PL Niezbędne elementy |
| DE Benötigte Teile | SL Dele, ki jih boste potrebovali | RO Elementele componente necesare |
| ES Piezas necesitadas | HR Dijelovi potreban | BG Необходими части |
| PT Peças Necessárias | HU Szükséges részek | TR Gerekli parçalar |
| NL Onderdelen nodig | SV Delar som behövs | |

DLJ	1	L	1
DRJ	1	R	1
LH↑	2	SGC1	20
RH↑	2	PW	20



1

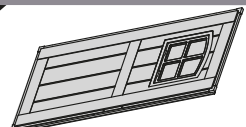

DLJ (x1)

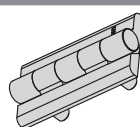

LH↑ (x2)



SGC1 (x4)



PW (x4)

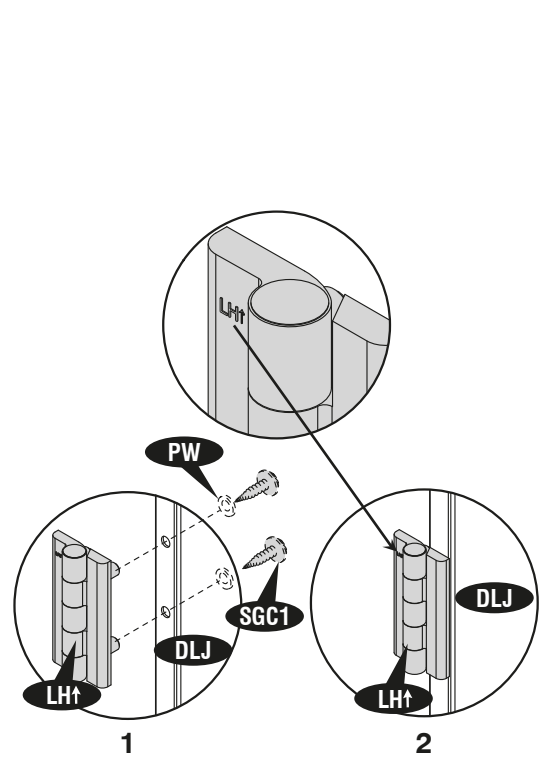

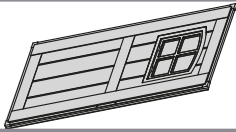

- | |
|---------------------|
| EN Left Door |
| FR Porte gauche |
| DE Linke Tür |
| ES Puerta izquierda |
| PT Porta esquerda |
| NL Linker deur |
| CS Levé dveře |
| SK Ľavé dvere |
| SL Leva vrata |
| HR Lijeve vrata |
| HU Bal ajtó |
| SV Vänster dörr |
| IT Porta Sinistra |
| PL Lewe drzwi |
| RO Usa stanga |
| BG Лява врата |
| TR Sol kapı |

2

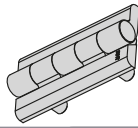

DRJ (x1)



RH↑ (x2)



SGC1 (x4)



PW (x4)

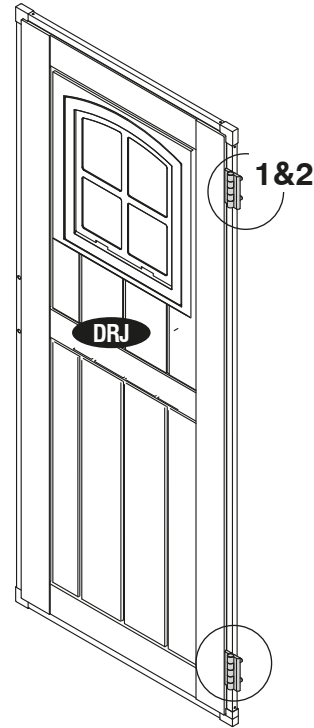
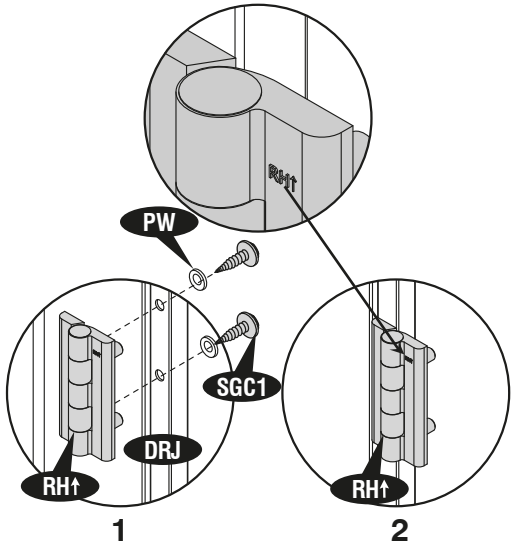

- EN Right Door
- FR Porte droite
- DE Rechte Tür
- ES Puerta derecha
- PT Porta direita
- NL Rechter deur
- CS Pravé dveře
- SK Pravé dvěre
- SL Desna vrata
- HR Desna vrata
- HU Jobb ajtó
- SV Höger dörr
- IT Porta Destra
- PL Prawe drzwi
- RO Usa dreapta
- BG Дясна врата
- TR Sağ kapı



3



SGC1 (x8)



PW (x8)

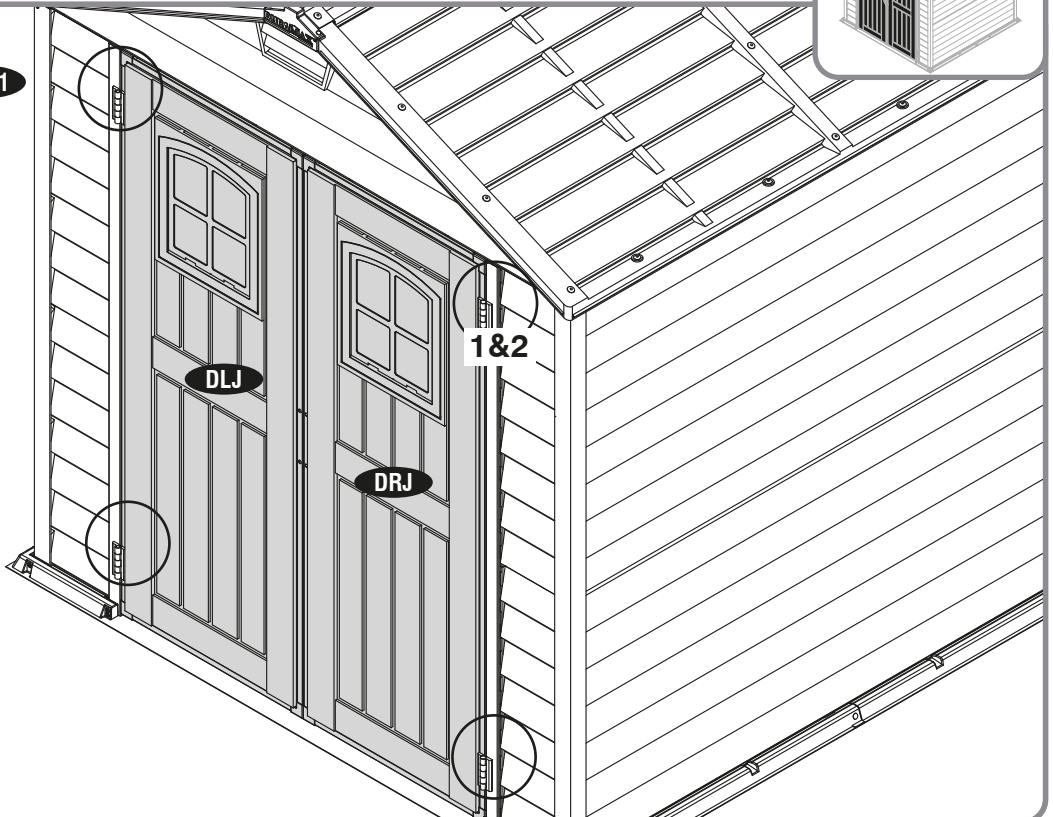
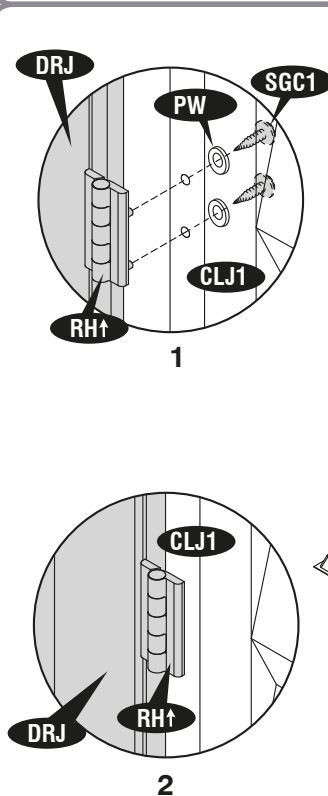

4

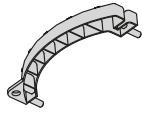

L (x1)

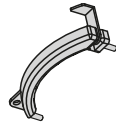

R (x1)



SGC1 (x4)



PW (x4)

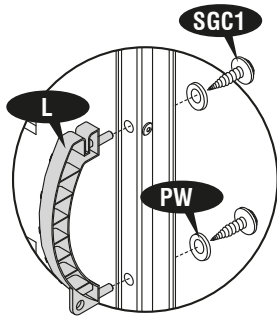

1

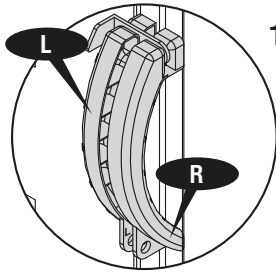

1

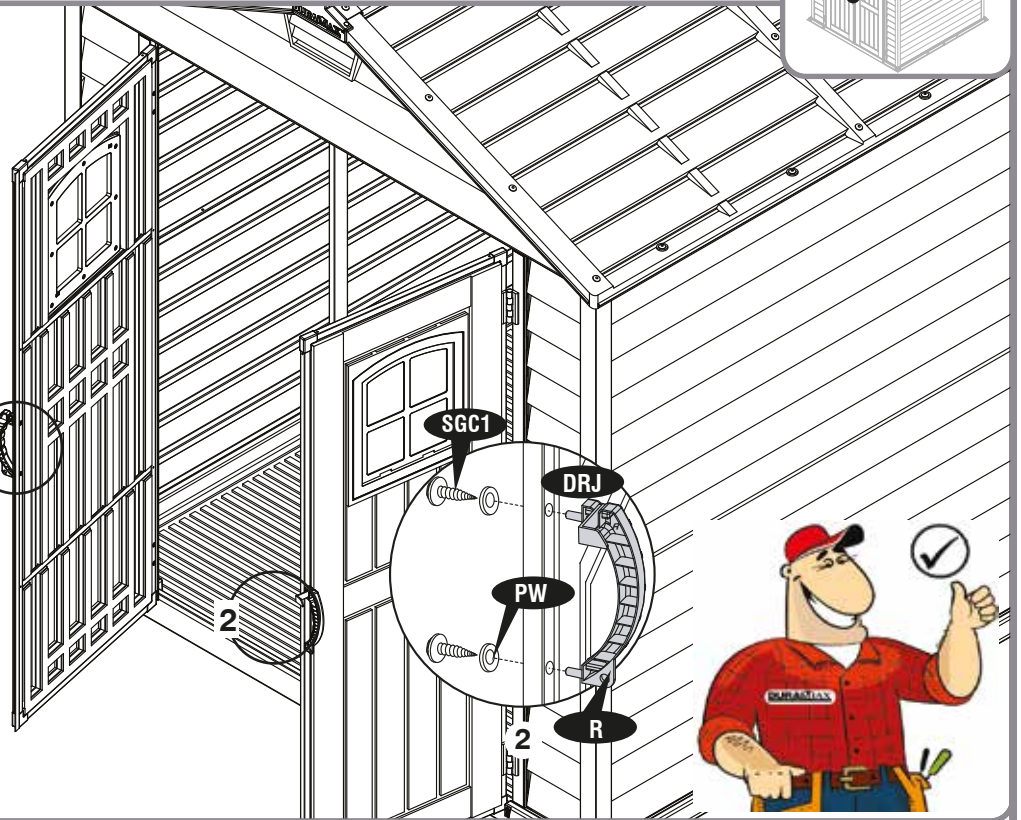

2

2

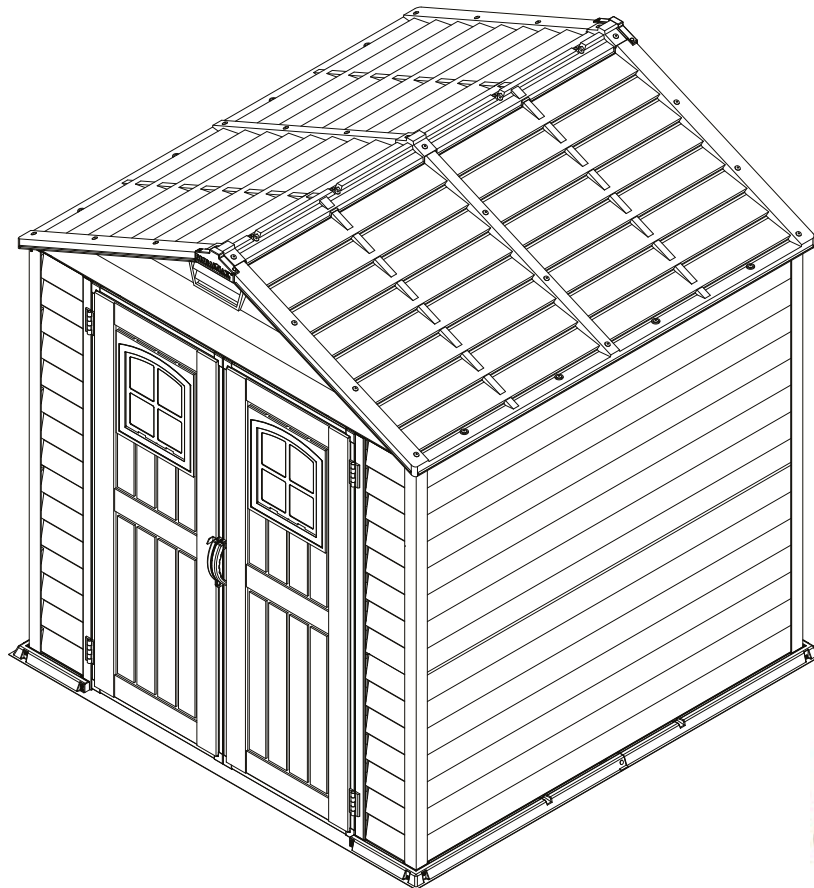

EN Assembly on Concrete Platform	CS Montáž na betonové plošině	IT Montaggio su piattaforma in calcestruzzo
FR Assemblage sur plate-forme en béton	SK Montáž na betónovú plošinu	PL Montaż na betonowej platformie
DE Montage auf Betonplattform	SL Montaža na betonsko ploščad	RO Adunarea pe platforma de beton
ES Montaje en plataforma de hormigón	HR Montaža na betonskoj platformi	BG Монтаж на бетонна платформа
PT Montagem em plataforma de concreto	HU Szerelés beton felületen	TR Beton platform üzerine montaj
NL Montage op betonplatform	SV Montering på betongplattform	



EN Parts needed	CS Potřebné součásti	IT Parti occorrenti
FR Pièces nécessaires	SK Potrebné časti	PL Niezbędne elementy
DE Benötigte Teile	SL Dele, ki jih boste potrebovali	RO Elementele componente necesare
ES Piezas necesitadas	HR Dijelovi potreban	BG Необходими части
PT Peças Necessárias	HU Szükséges részek	TR Gerekli parçalar
NL Onderdelen nodig	SV Delar som behövs	

S2	6
S6	6
F1	6



EN To ensure that your shed withstands high winds, we recommend using this floor option. A concrete pad or large size concrete patio stone squares is recommended for suitable floor base. Make sure it is firm and level and will allow drainage away from the site. Make a level concrete foundation, that has an outside dimension of 86 7/8" x 86 7/8" (2206mm x 2206mm), for Basic Shed. **For a concrete pad base, prepare a level bed for a firm footing layer of crushed stone. The concrete pad should then be poured to a thickness of 4 inches (100mm) to 5 inches (125mm). Allow to dry thoroughly for at least 48 hours. Manufacturer is not responsible for the choice and construction of the foundation.**

FR Pour vous assurer que votre hangar résiste à des vents violents, nous avons recommandé d'utiliser cette option de plancher. Une dalle de béton ou une grande taille concrètes dalles de patio de est recommandé pour base appropriée au sol. Assurez-vous qu'il est ferme et niveau et permettre un bon drainage du site. Faire niveau fondation en béton, qui a une dimension extérieure de 86 7/8" x 86 7/8" (2206mm x 2206mm). Pour hanger de base.

Pour une dalle en béton, préparer une couche de graviers de nive au. Le tampon de béton doit ensuite être coulé sur une épaisseur de 4 pouces (100 mm) à 5 pouces (125 mm). Laisser sécher complètement pendant au moins 48 heures. Le fabricant n'est pas responsable du choix et de la construction des fondations.

DE Um sicherzustellen, dass Ihr Schuppen hohen Winden standhält, empfiehlt es sich, diese Bodenoption zu benutzen. Dieser Geräteschuppen sollte auf einem festen Untergrund (wie zum Beispiel einer Betonfläche oder Waschbetonplatten) aufgebaut werden. Stellen Sie sicher, dass eine Entwässerung der Aufstellfläche gewährleistet ist. Erstellen sie ein ebenes Betonfundament, mit den Außenmaßen 86 7/8" x 86 7/8" (2206mm x 2206mm)..

Füllen Sie eine Kiesschicht ein und verdichten Sie diese (ggf. mit einer Rüttelplatte). Giesen Sie den Beton gleichmäßig ein, die Dicke sollte 100mm bis 125mm betragen. Anschließend mindestens 48 Stunden trocknen lassen. Der Hersteller ist nicht für die Auswahl des Fundaments verantwortlich

ES Para asegurarse de que su cobertizo resiste vientos fuertes, se recomienda utilizar esta opción baja. Un cojín concreto o los cuadrados concretos del tamaño grande de una piedra del patio se recomiendan para la base conveniente para el suelo. Asegúrese de que sea firme y llana y que permita drenaje lejos del sitio. Hacer una fundación nivel concreto que tiene una dimensión fuera de 86 7/8" x 86 7/8" (2206mm x 2206mm). cobertizo para Básico.

Para una base concreta del cojín, prepare una cama llana para una capa de pie firme de la piedra machacada. El cojín concreto se debe entonces verter a un grueso de 4 pulgadas (100mm) a 5 pulgadas (125mm). Permita secarse a fondo por lo menos 48 horas. El fabricante no es responsable de la opción y de la construcción de la fundación.

PT Para garantir que o seu galpão resiste a ventos fortes, recomendamos usar esta opção de andar. Um bloco de concreto ou um quadrados de pedra de pátio de concreto de tamanho grande é recomendado para base apropriado do assoalho. Certifique-se que é firme e nivelada e permitirá drenagem longe do local. Fazer base de uma fundação de concreto nível, que tem uma dimensão exterior de 86 7/8" x 86 7/8" (2206mm x 2206mm).

Em um bloco de concreto, preparar uma cama de nível para uma camada firme de brita. O base de concreto deve ser derramado em seguida a uma espessura de 4 polegadas (100mm), 5 polegadas (125mm). Deixe para secar completamente pelo menos 48 horas. Fabricante não é responsável pela escolha e construção da Fundação.

NL Om ervoor te zorgen dat uw schuur bestand is tegen hoge winden, raden wij u aan deze vloeroptie te gebruiken. Een concrete pad of een groot formaat concrete patio stenen pleinen wordt aanbevolen voor geschikt woord basis. Zorg ervoor dat het is stevig en niveau en drainage zal toestaan weg van de site. Een niveau concrete stichting, die een externe dimensie van 86 7/8" x 86 7/8" (2206mm x 2206mm).

For a concrete pad base, prepare a level bed for a firm footing layer of crushed stone. The concrete pad should then be poured to a thickness of 4 inches (100mm) to 5 inches (125mm). Allow to dry thoroughly for at least 48 hours. Manufacturer is not responsible for the choice and construction of the foundation.

CS Abyste zajistili, že váš haly odolává silnému větru, doporučujeme použít tuto podlahu. Pro vhodnou podlahovou základnu se doporučuje betonová podložka nebo velké betonové terasové čtverce. Ujistěte se, že je pevný a rovný a umožní odvodnění od místa. Vyrobtte hladký betonový podklad, který má vnější rozměr 86 7/8" x 86 7/8" (2206mm x 2206mm), pro základní shed.

U betonové podložky připravte rovnou lůžko pro pevnou podkladovou vrstvu drceného kamene. Betonová vložka by měla být nalita do tloušťky od 100 palců do 5 palců (125 milimetrů). Nechte důkladně vyschnout po dobu nejméně 48 hodin. Výrobce nezodpovídá za volbu a výstavbu nadace.

SK Aby ste zabezpečili, že vaša haly odolá vysokému vetru, odporúčame použiť túto podlahovú možnosť.
Na vhodnú podlahovú základňu sa odporúča betónová podložka alebo veľké betónové terasové kamenné štvorce. Uistite sa, že je pevný a rovný a umožní odvodnenie z miesta. Vytvorte základový betónový základ, ktorý má vonkajší rozmer 86 7/8" x 86 7/8"(2206mm x 2206mm). pre základňu. **Pre betónovú podložku pripravte hladkú vrstvu pre pevnú základovú vrstvu drveného kameňa. Betónová podložka by mala byť potom naliatá do hrúbky 4 palce (100 mm) až 5 palcov (125 mm). Nechajte dôkladne vysušiť aspoň 48 hodín. Výrobca nie je zodpovedný za výber a výstavbu nadácie.**

SL Da bi zagotovili, da bo vaša hiša odtegnila visoke vetrove, smo priporočili, da uporabite to možnost.
Za primerne talne podlage je priporočljiva betonska podloga ali betonski trgi z velikimi površinami. Prepričajte se, da je čvrsta in raven ter omogočila drenažo stran od mesta. Izdelajte ravno betonsko podlogo, ki ima zunanjo dimenzijo dimenzij 86 7/8" x 86 7/8"(2206mm x 2206mm). za Basic Shed. **Za betonsko podlogo pripravite ravno posteljo za trdno podlogo iz drobljenega kamna. Betonsko ploščo je treba nato vliiti do debeline 4 palcev (100 mm) do 5 palcev (125 mm). Pustite, da se temeljito posuši najmanj 48 ur. Proizvajalec ni odgovoren za izbiro in gradnjo temeljev.**

HR Da bismo osigurali da vaš prolaz izdrži jak vjetar, preporučujemo da upotrijebite tu podu.
Za pogodnu podnu bazu preporučuje se betonska podloga ili velike kamene ploče od betona. Pobrinite se da je čvrsta i razina i omogućit će odvod daleko od stranice. Izradite temeljni betonski temelj koji ima vanjsku dimenziju od 86 7/8" x 86 7/8"(2206mm x 2206mm). za Basic Shed. **Za betonsku podlogu, pripremite krevet na razini za čvrsto podnožje slomljenog kamena. Betonsku podlogu treba zatim izliti na debljinu od 100 mm do 125 inča. Ostavite temeljito suhom najmanje 48 sati. Proizvođač nije odgovoran za odabir i izgradnju zaklade.**

HU Annak érdekében, hogy a fészter ellenálljon a magas szeleknek, javasoljuk, hogy használja ezt a padlót.
Betonpárna vagy nagyméretű betonpadló kőpadok ajánlottak megfelelő padlóalapra. Győződjön meg arról, hogy szilárd és vízszintes, és lehetővé teszi a vízelvezetést távol a helyszíntől. Végezzünk el egy szintetikus alapot, amely 86 7/8" x 86 7/8"(2206mm x 2206mm). külső méretekkel rendelkezik a Basic Shed számára. **Betonpárnás aljzat esetén készítsen egy szintes ágyat egy szilárd alapozórétre. A betonpárnát ezután 100 mm-es és 125 mm-es vastagságúra kell önteni. Legalább 48 órán keresztül hagyja alaposan száradni. A gyártó nem vállal felelősséget az alapítvány kiválasztásához és megépítéséért.**

SV För att säkerställa att din skjul tål hög vind rekommenderar vi att du använder det här golvalternativet.
En betongkudde eller en stor betongplattform stenplattor rekommenderas för lämplig golvyta. Se till att den är fast och jämn och gör det möjligt att dränera bort från platsen. Gör en jämn betongfundament, som har en yttre dimension av 86 7/8" x 86 7/8"(2206mm x 2206mm). för Basic Shed. **För en betongplatta bas, förbereda en nivå säng för ett fast fotskikt av krossad sten. Betongplattan ska sedan hållas till en tjocklek av 4 tum (100 mm) till 5 tum (125 mm). Låt torka noggrant i minst 48 timmar. Tillverkaren ansvarar inte för valet och bygandet av stiftelsen.**

IT Per garantire che il tuo capannone sopporta venti elevati, abbiamo consigliato di utilizzare questa opzione a pavimento.
Si consiglia un tappetino in calcestruzzo o un quadrato in pietra di cemento in grande formato per una base adatta. Assicurarsi che sia stabile e livellato e permetterebbe di drenare lontano dal sito. Realizzare una base di calcestruzzo di livello, che ha una dimensione esterna di 86 7/8" x 86 7/8"(2206mm x 2206mm). per Basic Shed. **Per una base di rilievo in calcestruzzo, preparare un letto a livello per un solido strato di pietra schiacciata. Il tappetino di calcestruzzo deve quindi essere versato ad uno spessore da 100 mm a 125 centimetri. Lasciare asciugare accuratamente per almeno 48 ore. Il produttore non è responsabile della scelta e della costruzione della fondazione.**

PL W celu zapewnienia, że szopy wytrzymują wysokie wiatry, zalecamy skorzystanie z tej opcji podłogi.
Betonu pad lub duży rozmiar konkretne patio kamień kwadratów jest zalecane dla odpowiedniej bazy pietra. Upewnij się, że to jest prosto i stabilnie i pozwoli drenaż witryny. Zrobić fundamentie betonowym poziom, który ma wymiar zewnętrzny 86 7/8" x 86 7/8"(2206mm x 2206mm).. **Do betonu pad podstawy, przygotować łóżko poziom dla firmy stopie warstwę tłuczni. Beton pad powinien być następnie przelewa się do grubości 4 cali (100mm) do 5 cali (125mm). Pozostawić do wyschnięcia dokładnie na co najmniej 48 godzin. Producent nie jest odpowiedzialny za wybór i budowie fundamentów.**

RO Pentru a vă asigura că vaporul dvs. rezistă unor vânturi puternice, am recomandat să folosiți această opțiune pentru podea.
Un tampon de beton sau o pătrată de piatră din beton de dimensiuni mari este recomandată pentru o bază adecvată pentru podea. Asigurați-vă că este ferm și la nivel și va permite scurgerea departe de site. Asigurați o fundație de beton de nivel, care are o dimensiune exterioară de 86 7/8" x 86 7/8"(2206mm x 2206mm). pentru Shed Basic. **Pentru o bază de bază de beton, pregătiți un pat de nivel pentru un strat ferm de piatră zdrobită. Plăcuța de beton trebuie apoi turnată la o grosime de 4 inci (100 mm) până la 5 inci (125 mm). Lăsați-l să se usuce bine timp de cel puțin 48 de ore. Producătorul nu este responsabil pentru alegerea și construirea fundației.**

BG За да сте сигурни, че Вашата барака издържа високи ветрове, препоръчваме да използвате тази опция за пода.
За подходяща подова основа се препоръчва използването на бетонна подложка или големи бетонни квадратни плочки. Уверете се, че тя е здрава и равна и ще позволи дренаж далеч от мястото. Направете нивелирана бетонна основа, която има външен размер от 86 7/8" x 86 7/8"(2206mm x 2206mm). за основен навес. **За бетон основа на подложка, подгответе ниво легло за твърда основа слой от натрошен камък. След това бетонната подложка трябва да се излива на дебелина от 4 инча (100 mm) до 5 инча (125 mm). Оставете да изсъхне напълно за поне 48 часа. Производителят не носи отговорност за избора и изграждането на основата.**

TR Sunduğunuzdan yüksek rüzgarlara dayanıklı olmasını sağlamak için bu zemin seçeneğini kullanmanızı öneririz.
Uygun taban tabanı için beton bir yastık veya büyük boy bir beton bahçe avlusu karosu önerilir. Sert ve sağlam olduğundan ve drenajın yerinden uzaklaşmasına izin vereceğinden emin olun. Basic Shed için dış boyut 86 7/8" x 86 7/8"(2206mm x 2206mm). olan düz bir beton temel oluşturun. **Beton pad taban için, ezilmiş taşın sağlam bir taban tabakası için düz bir yatak hazırlayın. Beton pedi daha sonra 4 inç (100mm) ila 5 inç (125mm) arasındaki bir kalınlığa dökülmelidir. En az 48 saat boyunca iyice kurummasına izin verin. Üretici, vakfın seçimi ve yapımı için sorumlu değildir.**





F1 (x6)



S2 (x6)



S6 (x6)

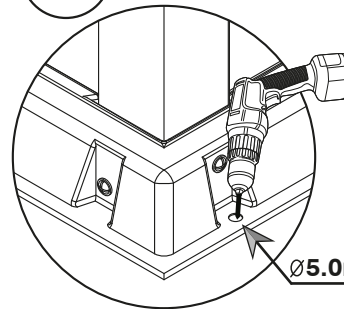
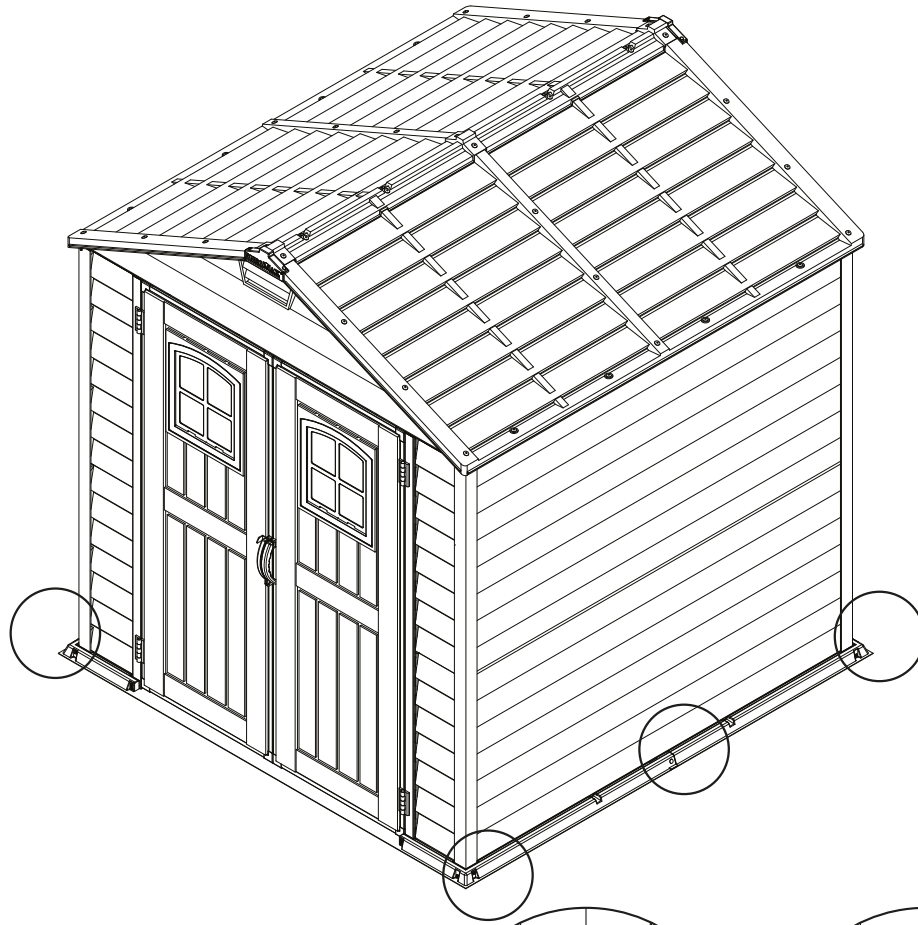

Ø5.0mm.

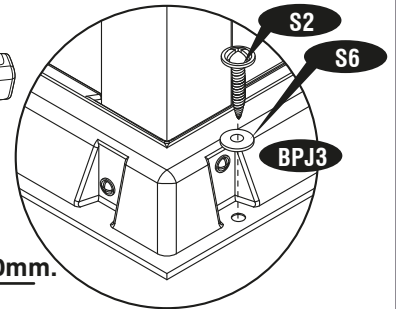

- (EN) Concrete
- (FR) Béton
- (DE) Beton
- (ES) Hormigón
- (PT) Concreto
- (NL) Beton
- (CS) Beton
- (SK) Beton
- (SL) Beton
- (HR) Beton
- (HU) Konkrét
- (SV) Betong
- (IT) Calcestruzzo
- (PL) Beton
- (RO) Beton
- (BG) бетон
- (TR) Beton

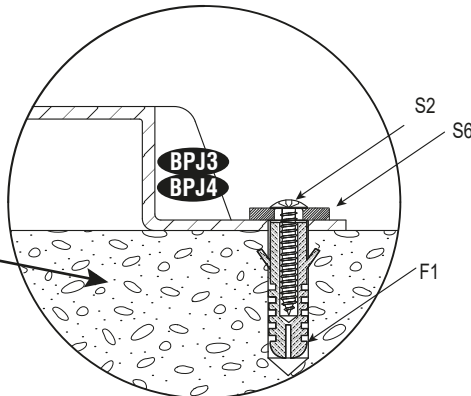

EN Important Warranty Information

FR Informations Importantes Concernant La Garantie

DE Wichtige Informationen zur Gewährleistung

ES Información importante sobre la garantía

PT ImportantesInformações de Garantia

NL Belangrijke Informatie over de garantie

CS Důležitá informace o záruce

SK Dôležitá informácie o záruke

SL Pomembne Garancijske Informacije

HR Važne informacije o jamstvu

HU Fontos jótállási információk

SV Viktig garantiinformation

IT Informazioni importanti sulla garanzia

PL Ważne informacje gwarancyjne

RO Informații importante privind garanția

BG Важна информация за гаранцията

TR Önemli Garanti Bilgileri



EN The 'DURAMAX' shed has been tested and passed high wind loads in a controlled laboratory environment when installed with the high wind installation guidelines. Natural high wind areas create wind at unpredictable speeds that are very difficult to capture accurately by location. As such we cannot guarantee the performance of the shed in these extreme situations

FR Le hangar ' DURAMAX ' a été testé et passé des charges de vent élevées dans un environnement de laboratoire contrôlé lorsqu'il est installé avec les directives d'installation de haute vent . Naturelles, les zones de vents forts créent vent à des vitesses imprévisibles qui sont très difficiles à saisir avec précision par emplacement . En tant que tel , nous ne pouvons pas garantir la performance de la foule dans ces situations.

DE Das "DURAMAX" -Haus wurde getestet und hat hohe Windlasten in einer kontrollierten Laborumgebung bestanden, wenn es mit den Richtlinien für hohe Windinstallationen installiert wurde. Natürliche Starkwindgebiete erzeugen Wind mit unvorhersehbaren Geschwindigkeiten, die aufgrund des Standorts nur schwer erfasst werden können. Daher können wir die Leistung des Schuppens in diesen extremen Situationen nicht garantieren.

ES El cobertizo ' DURAMAX ' ha sido probado y aprobado cargas de viento en un entorno controlado de laboratorio cuando se instala con las pautas de instalación de vientos fuertes . Espacios naturales de vientos crean viento a velocidades impredecibles que son muy difíciles de capturar con precisión la ubicación. Como tal , no podemos garantizar el funcionamiento de la nave en.

PT O galpão 'DURAMAX' foi testado e passou por altas cargas de vento em um ambiente de laboratório controlado quando instalado com as diretrizes de instalação de alta energia eólica. As áreas naturais de ventos fortes criam vento a velocidades imprevisíveis que são muito difíceis de capturar com precisão por localização. Como tal, não podemos garantir o desempenho do galpão nessas situações extremas

NL Het 'DURAMAX'-schuurtje is getest en heeft hoge windbelastingen doorstaan in een gecontroleerde laboratoriumomgeving, indien geïnstalleerd met de richtlijnen voor hoge winden. Natuurlijke windrijke gebieden creëren wind met onvoorspelbare snelheden die zeer moeilijk nauwkeurig op locatie kunnen worden vastgelegd. Als zodanig kunnen we de prestaties van de schuur in deze extreme situaties niet garanderen

CS Ústředna DURAMAX byla testována a prošla vysokým zatížením větrem v kontrolovaném laboratorním prostředí, když byla instalována s pokyny pro větrnou instalaci. Přírodní větrné plochy vytvářejí vítr při nepředvídatelných rychlostech, které je velmi obtížné přesně zachytit podle místa. Jako takové nemůžeme zaručit výkon haly v těchto extrémních situacích

SK Dúchadlá "DURAMAX" boli testované a prešli vysokou záťažou vetra v kontrolovanom laboratórnom prostredí, keď sú inštalované so smernicami pre vysoký vietor. Prírodné oblasti s vysokým vetrom vytvárajú vietor pri nepredvídateľných rýchlostiach, ktoré sa veľmi ťažko zachytia presne podľa miesta. Ako taký nemôžeme zaručiť výkonnosť kóline v týchto extrémnych situáciách

SL Preskus "DURAMAX" je bil preizkušeni in prešel velike obremenitve vetra v nadzorovanem laboratorijskem okolju, če je bil nameščen s smernicami za visoko vetrove. Naravni viri vetra ustvarijo veter ob nepredvidljivih hitrostih, ki jih je zelo težko natančno zajemati glede na lokacijo. Kot taka ne moremo zagotoviti učinkovitosti skladišča v teh skrajnih razmerah

HR Prostor "DURAMAX" je testiran i prošao velike opterećenja vjetrom u kontroliranom laboratorijskom okruženju kada je instaliran s visokim smjernicama za instalaciju vjetra. Prirodni visoki vjetrojevi stvaraju vjetar na nepredvidljivim brzinama koje su vrlo teško točno snimiti po lokaciji. Kao takav ne možemo jamčiti izvedbu prolivenih u ovim ekstremnim situacijama

HU A DURAMAX fészerté ellenőrzött laboratórium környezetben tesztelték, és nagy szélterhelést vezettek be, amikor a nagy szélsőkapási irányelvekkel telepítették. A természeti nagy szélterületek olyan kiszámíthatatlan sebességű szélsősebességet hoznak létre, amelyet nagyon nehéz rögzíteni helyesen a helyszínen. Így nem garantálhatjuk a fészerteljesítményét ebben a szélsőséges helyzetben

SV DURAMAX-skjulet har testats och passerat höga vindbelastningar i en kontrollerad laboratoriemiljö när den installeras med riktlinjerna för hög vindkraft. Naturliga höga vindområden skapar vind med oförutsägbara hastigheter som är mycket svåra att fånga noggrant på plats. Som sådan kan vi inte garantera skurets prestanda i dessa extrema situationer

IT Il capannone 'DURAMAX' è stato testato e ha superato carichi di vento elevato in un ambiente di laboratorio controllato quando installato con le linee guida per l'installazione del vento forte. Le aree naturali del vento forte creano vento a velocità imprevedibili che sono molto difficili da catturare con precisione in base alla posizione. Pertanto non possiamo garantire le prestazioni del capannone in queste situazioni estreme





- PL** Szopa "DURAMAX" została przetestowana i przeszła duże obciążenia wiatrem w kontrolowanym środowisku laboratoryjnym, gdy zainstalowano ją zgodnie z wytycznymi dotyczącymi instalacji wiatrowej. Naturalne obszary o dużym natężeniu wiatru wytwarzają wiatr o nieprzewidywalnych prędkościach, które są bardzo trudne do uchwycenia dokładnie według lokalizacji. W związku z tym nie możemy zagwarantować wykonania szopy w tych ekstremalnych sytuacjach.
- RO** Dulapul "DURAMAX" a fost testat și a fost încărcat cu încărcături puternice de vânt într-un mediu de laborator controlat atunci când este instalat cu instrucțiunile de instalare a vântului. Zonele naturale cu vânt puternic creează vânt la viteze imprevizibile, care sunt foarte greu de capturat cu precizie în funcție de locație. Ca atare, nu putem garanta performanța magazinului în aceste situații extreme
- BG** Тръбопроводът "DURAMAX" е тестван и преминава в силно натоварване от вятър в контролирана лабораторна среда, когато е инсталиран с насоките за вятърна инсталация. Природните високи ветрови зони създават вятър при непредсказуеми скорости, които са много трудни за улавяне по точно местоположение. Като такива не можем да гарантираме изпълнението на навеса в тези крайни ситуации
- TR** "DURAMAX" dökümü, yüksek rüzgar tesisatı kurallarına göre kurulduğunda kontrollü bir laboratuvar ortamında yüksek rüzgar yüklerini test etti ve geçti. Doğal yüksek rüzgârlı bölgeler, konuma göre hassas bir şekilde yakalanması çok zor olan, öngörülemeyen hızlarda rüzgar yaratır. Bu nedenle, bu olağanüstü durumlarda kulübenin performansını garanti edemeyiz.



- EN** "For dismantling the Shed, Customer has to follow instructions manual in reverse direction."
- FR** "Pour le démantèlement du hangar, client doit suivre le manuel d'instructions dans le sens inverse."
- DE** In Gebieten mit starken Schneefällen oder starkem Wind empfehlen wir das nachstehende Zubehör.
- ES** "Para el desmantelamiento de la nave, cliente tiene que seguir instrucciones en sentido contrario".
- PT** "Para desmontar o galpão, cliente tem de seguir o manual de instruções em sentido reverso".
- NL** "Voor de ontmanteling van de schuur, klant heeft te volgen instructiehandleiding in omgekeerde richting."
- CS** 'Pro demontáž přístřešku musí zákazník postupovat podle pokynů v opačném směru.'
- SK** 'Pri demontáži prístrešku musí zákazník postupovať podľa pokynov v opačnom smere.'
- SL** 'Za demontažo skladišča mora naročnik slediti priročniku v obratni smeri.'
- HR** 'Za demontažu zida, korisnik mora slijediti priručnike za upute u obrnutom smjeru.'
- HU** 'A fészter lebontásához az Ügyfélnek vissza kell követnie az utasításokat.'
- SV** 'För att demontera Shed måste kunden följa instruktionsboken i omvänd riktning.'
- IT** 'Per lo smontaggio del capannone, il cliente deve seguire manualmente le istruzioni in senso inverso'..
- PL** do demontażu szopy, należy postępować zgodnie z instrukcją obsługi w odwrotnym kierunku
- RO** 'Pentru dezmembrarea Shedului, Clientul trebuie să urmeze manualul de instrucțiuni în sens invers.'
- BG** 'За демонтиране на навеса клиентът трябва да следва инструкциите в наръчник в обратна посока.'
- TR** 'Shed'in sökülmesi için, Müşteri yönergeleri ters yönde takip etmelidir.'



- EN** ADDITIONAL ACCESSORIES AVAILABLE
(Not included)
- FR** ACCESSOIRES ADDITIONNELS DISPONIBLES
(non inclus)
- DE** WEITERES ZUBEHÖR
(Nicht enthalten)
- ES** ACCESORIOS ADICIONALES DISPONIBLES
(no incluida)
- PT** ACESSÓRIOS ADICIONAIS DISPONÍVEIS
(não incluído)
- NL** EXTRA ACCESSOIRES AANWEZIG.
(niet inbegrepen)
- CS** MOŽNÉ DALŠÍ DOPLŇKY.
(není součástí balení)
- SK** DOSTUPNÉ DODATOČNÉ PRÍSLUŠENSTVO
(nie je súčasťou balenia)
- SL** RAZPOLOŽLJIVA DODATNA OPREMA
(niso vključene)
- HR** DODATNI PROGRAMI RASPOLOŽIV
(nije uključeno)
- HU** TOVÁBBI MEGVÁSÁROLHATÓ TARTOZÉKOK
(nem tartozék)
- SV** YTTERLIGARE TILLGÄNGLIGA ACCESSOARERV
(ingår ej)
- IT** ACCESSORI SUPPLEMENTARI DISPONIBILI
(non incluso)
- PL** DOSTĘPNE DODATKOWE AKCESORIA
(nie wliczone)
- RO** ACCESORIILE SUPLIMENTARE DISPONIBILE
(Nu este inclus)
- BG** ДОПЪЛНИТЕЛНИ НАЛИЧНИ АКЕСОАРИ
(не е включен)
- TR** EK AKSESUARLAR MEVCUTTUR
(dahil değildir)



- EN** These accessories are required in case of heavy snow or high wind areas. Please choose relevant accessories according to your needs.
- FR** Ces accessoires sont exigés en cas de zones de la neige forte ou du vent fort. Veuillez choisir les accessoires appropriés selon vos besoins.
- DE** In Gebieten mit starken Schneefällen oder starkem Wind empfehlen wir das nachstehende Zubehör.
- ES** Estos accesorios son requeridas en caso de fuertes nevadas o zonas de alto viento. Por favor, elija los accesorios pertinentes de acuerdo a sus necesidades.
- PT** Estes acessórios são necessários em áreas de vento forte e/ou neve. Por favor, escolha os acessórios pertinentes de acordo com suas necessidades.
- NL** Deze accessoires zijn nodig in geval van hevige sneeuw val of gebieden waar het hard waait. Gebruik de accessoires die u nodig heeft.
- CS** Tyto doplňky se vyžadují v místech s velkým množstvím sněhu či silným větrem. Zvolte si prosím příslušné doplňky podle vašich potřeb.
- SK** Toto príslušenstvo sa vyžaduje v prípadoch ťažkého a veľkého množstva snehu alebo silného vetra. Vyberte si relevantné príslušenstvo na základe vašich potrieb.
- SL** Ta dodatna oprema se uporablja v primeru velike količine zapadlega snega ali če lopa stoji na zelo vetrovnem območju. Izberite ustrezno opremo glede na to, kaj dejansko potrebujete.
- HR** Ovi dodaci su potrebni u slučaju teškog snijega ili jak vjetar regija. Molimo odaberite relevantne dodatne opreme prema vašim potrebama.
- HU** Ezekre a tartozékokra sürű havazás esetén vagy erősen szeles területeken van szükség. Kérjük, igénye szerint válasszon a megfelelő tartozékok közül.
- SV** Dessa accessoarer behövs vid tung snö eller i områden med hård vind. Var god välj relevanta accessoarer efter behov.
- IT** Questi accessori sono importanti in caso di neve o aree soggette a forti venti. Per favore, scegli questi accessori in base ai tuoi bisogni.
- PL** Akcesoria te są wymagane w przypadku terenów, na których zdarzają się duże opady śniegu lub silniewiatry. Wybierz odpowiednie akcesoria w zależności od potrzeb.
- RO** Aceste accesorii sunt necesare în cazul în cazul în care apar depuneri masive de zăpadă sau în zonele în care bate vânt puternic. Vă rugăm alegeți accesorii potrivite nevoilor dumneavoastră.
- BG** Тези аксесоари се изискват в случай на тежък сняг или при райони със силен вятър. Моля подберете съответните аксесоари според нуждите.
- TR** Bu aksesuarlar yoğun kar yağışı ya da kuvvetli rüzgar alan bölgelerde gereklidir. Lütfen ihtiyaçlarınıza uygun gerekli aksesuarları seçiniz.

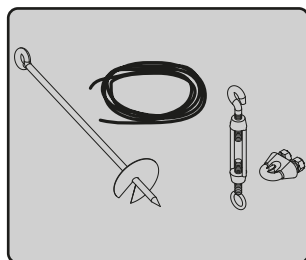

1

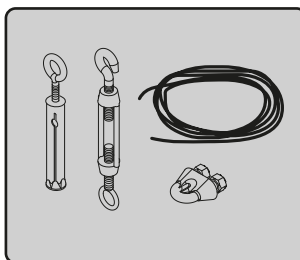

2

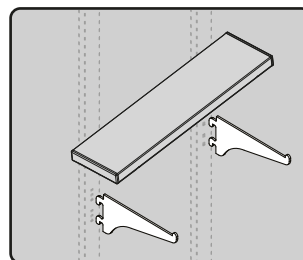

3

1

- | | |
|------------------------------------|--------------------------------|
| EN ANCHOR KIT (Soil) | HR SIDRO KOMPLET (tla) |
| FR KIT D'ANCRE (Sol) | HU RÖGZÍTŐ FELSZERELÉS (Talaj) |
| DE ANKER-KIT (Boden) | SV FÖRANKRINGS-KIT (Jord) |
| ES KIT DE ANCLAJE (Suelo) | IT KIT DI ANCORAGGIO (Suolo) |
| PT KIT DE APOIO (Solo) | PL ZESTAW DO MOCOWANIA (Grunt) |
| NL ANKER GEREEDSCHAP (bodem) | RO SET DE ANCORARE (ÎN SOL) |
| CS KOTEVNÍ SOUPRAVA (Hlína) | BG КОМПЛЕКТ АНКЕРИ (Почва) |
| SK UKOTVOVACIE PRÍSLUŠENSTVO (zem) | TR EKLEMLEME KİTİ (Toprak) |
| SL SIDRNA OPREMA (zemlja) | |

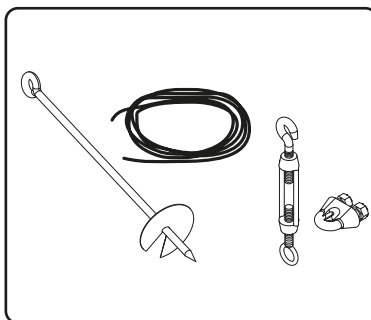

- EN** Wire rope with twist augers for sheds installed with foundation (Wood / Metal) on soil.
For heavy wind area.
- FR** Fil de fer avec des foreuses de torsion pour des hangars installés avec la base (en métal / en bois) sur le sol. **Pour la zone du vent fort.**
- DE** Seil mit Erdbohrer bei einem Unterbau (Holz / Metall) auf dem Boden.
Für Gebiete mit starkem Wind.
- ES** El cable metálico para casetas instaladas con kit de estructura de suelo fijada al terreno.
- PT** Cabo metálico com brocas para galpões instalados com base (Madeira/Metal) em solo.
Para áreas de vento forte.
- NL** Bedrading met kronkelige grondboren voor het schuurtje moet met fundering worden geïnstalleerd (hout/metaal) op bodem. **Voor hevige wind gebieden.**
- CS** Drátěné lano se vrtáky pro kůlny postavené se základy (dřevo / kov) na hlíně.
Pro místa se silným větrem.
- SK** Drôténé lano s krútenými špirálovitými šnekmi pre hangáre nainštalované zo základom (drevo/kov) na zemi. **Pre oblasť so silným vetrom.**
- SL** Žična vrv z velikim svedrom z enojno spiralo za lope nameščene na temelju (les/kovina) na zemlji.
Za zelo vetrovna območja.
- HR** čelikčelo s okretati svrdlom za baca instaliran s temelja (Drvo / Metal) na tlu.
Za teške vjetar području.
- HU** Drótkötél spirálfúrókkal alappal rendelkező kerti fészerekhez (Fa / fém) talajon.
Erősen szeles területekre.
- SV** Wirelås med tvistborr för skjul installerade med grund (trä / metall) på jord.
För områden med hård vind.
- IT** Fune con trivella a spirale per capannoni installati con fondamenta (legno/metallo) sul suolo.
Per aree soggette a forte vento.
- PL** Lina stalowa ze świdrami dla magazynków montowanych na pod stawie (Drewno/Metal) do gruntu.
Przeznaczone do użytkowania na obszarach występowania silnych wiatrów.
- RO** Cabluri cu burghie răsucite pentru magazinele asamblate pe fundație (Lemn / Metal) în sol.
Pentru zonele în care bate vânt puternic.
- BG** Стоманено въже с извити сонди за заслони, монтирани върху фундаменти (Дърво / Метал) върху почва.
За силно ветровита зона.
- TR** Zemin (tahta/metal) toprak üstüne gelecek şekilde inşa edilen barnaklar için burgulu matkap ve tel ip.
Kuvvetli rüzgar alan yerler için.

2

- | | |
|--------------------------------------|--------------------------------|
| EN ANCHOR KIT (Concrete) | HR SIDRO KOMPLET (beton) |
| FR KIT D'ANCRE (Béton) | HU RÖGZÍTŐ FELSZERELÉS (Beton) |
| DE Verankerungsset (Beton) | SV FÖRANKRINGS-KIT (Betong) |
| ES KIT DE ANCLAJE (hormigón) | IT KIT DI ANCORAGGIO (cemento) |
| PT KIT DE APOIO (Concreto) | PL ZESTAW DO MOCOWANIA (Beton) |
| NL ANKER GEREEDSCHAP (Beton) | RO SET DE ACORARE (Beton) |
| CS KOTEVNÍ SOUPRAVA (Beton) | BG КОМПЛЕКТ АНКЕРИ (Бетон) |
| SK UKOTVOVACIE PRÍSLUŠENSTVO (betón) | TR EKLEMLEME KİTİ (Beton) |
| SL SIDRNA OPREMA (beton) | |

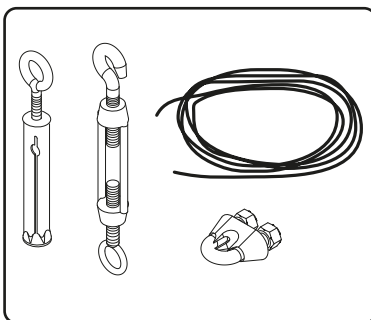

- EN** Eye bolt with wire rope for sheds installed with foundation (Wood / Metal) on concrete.
For heavy wind area.
- FR** OEil à queue filetée avec fil en fer pour des hangars installés avec la base (en métal / en bois) sur le béton.
Pour la zone du vent fort.
- DE** Ringschraube mit Seil für Gerätehäuser mit einem Unterbau (Holz / Metal) auf Beton.
Für Gebiete mit starkem Wind.
- ES** Coloque pernos de ojo y el cable metálico para las zonas de fuerte viento.
Para el área del fuerte viento.
- PT** Cavilha com cabo de aço para galpões instalados com base (Madeira/Metal) em concreto.
Para áreas de vento forte.
- NL** Eyebolt met stalendraad voor schuurtje moet worden geïnstalleerd met fundering (hout/metaal) op beton.
Voor hevige wind gebieden.
- CS** Oka s drátěným lanem pro kůlny postavené se základy (dřevo / kov) na betonu.
Pro místa se silným větrem.
- SK** Šrob s okom s drôteným lanom pre hangáre nainštalované so základom (drevo/kov) na betóne.
Pre oblasť so silným vetrom.
- SL** Očesni vijak z žično vrvjo za lope nameščene na temelju (les/kovina) na betonu.
Za zelo vetrovna območja.
- HR** oči vijak žičane užadi za baca Installer sa temelja (Drvo / Metal) na betonu.
Za teške vjetar području.
- HU** Gyűrűs csavar drótkötéllal alappal rendelkező kerti fészerekhez (Fa / fém) betonon.
Erősen szeles területekre.
- SV** Stagögla med wirelås för skjul som installerats med grund (Trä / Metall) på betong.
För områden med hård vind.
- IT** Vite ad occhiello con fune per capannoni installati con fondamenta (legno/metallo) sul cemento.
Per aree soggette a forte vento.
- PL** Śruba z uchem z liną stalową dla magazynków montowanych na podstawie (Drewno/Metal) do betonu.
Przeznaczony do użytkowania na obszarach występowania silnych wiatrów.
- RO** Şurub cu ochi ataşat la un cablu pentru magazinele asamblate pe fundaţie (Lemn / Metal) în beton.
Pentru zonele în care bate vânt puternic.
- BG** Шарнирен болт със стоманено въже за заслони, инсталирани с фундамент (Дърво / Метал) върху бетон.
За силно ветровита зона.
- TR** Zemin (tahta/metal) beton üstüne gelecek şekilde inşa edilen barınaklar için halkalı vida ve tel ip.
Kuvvetli rüzgar alan yerler için.

3

EN SHELF KIT

FR UN KIT D'ÉTAGÈRE

DE REGAL AUSSTATTUNG

ES KIT ESTANTE

PT KIT DE PRATELEIRAS

NL PLANK MONTAGE KIT

CS MONTÁŽNÍ SOUPRAVA POLIC

SK DOPLNKOVÝ KIT

SL KOMPLET POLIC

HR KUPANJE KIT

HU MINISÉGÉT KIT

SV HYLLA KIT

IT KIT MENSOLA

PL PÓŁKA KIT

RO SHELF KIT

BG КОМПЛЕКТ КОЛЕКЦИЯ

TR RAF KİTİ

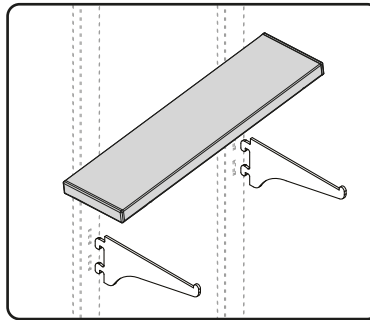

EN Slotted Channels are provided in the side vertical columns of the shed to mount the brackets for the shelf kit. 6 inch wide reinforced PVC shelf with Bracket and end caps.

FR Des rails à fentes sont fournis dans les colonnes verticales latérales de la remise pour monter les supports pour le kit d'étagères. Tablette renforcée en PVC de 6 pouces de largeur avec support et embouts.

DE In den seitlichen vertikalen Säulen des Schuppens sind Schlitzkanäle vorgesehen, um die Halterungen für das Regal-Kit zu montieren. 6 Zoll breites, verstärktes PVC-Regal mit Halterung und Endkappen.

ES Se proporcionan canales ranurados en las columnas verticales laterales del cobertizo para montar los soportes para el juego de estantes. Estante de PVC reforzado de 6 pulgadas de ancho con soporte y tapas finales.

PT Canais com fenda são fornecidos nas colunas verticais laterais do galpão para montar os suportes do kit de prateleira. Prateleira de PVC reforçado com 6 polegadas de largura com suporte e tampas.

NL In de verticale kolommen van de schuur zijn sleuven voorzien om de beugels voor de schapkit te monteren. 6 inch brede versterkte PVC-plank met beugel en eindkappen.

CS V bočních svislých sloupcích kůlny jsou šterbinové kanály pro připevnění držáků police. 6palcová vyztužená police z PVC s držákem a koncovkami.

SK V bočných zvislých stĺpkoch budy sú umiestnené drážkované kanály na pripevnenie konzol pre policovú súpravu. 6 palcov široká vyztužená PVC polica s konzolou a koncovými krytmi.

SL V stranskih navpičnih stolpcih lope so nameščeni kanali z režami za namestitev nosilcev kompleta polic. 6-palčna ojačana PVC polica z nosilcem in končnimi pokrovi.

HR Kanali s prorezima nalaze se u bočnim okomitim stupovima šupe za postavljanje nosača za komplet polica. Ojačana PVC polica od 6 inča široka s nosačem i završnim kapicama.

HU A fészertől oldalsó függőleges oszlopaiban réselt csatornák találhatók a polckészlet tartóinak felszereléséhez. 6 hüvelyk széles megerősített PVC polc konzollal és zárósapkákkal.

SV Slitsade kanaler finns i de vertikala sidokolonnerna på skjulet för att montera fästena för hyllsatsen. 6 tum bred förstärkt PVC-hylla med fäste och ändlock.

IT Nelle colonne verticali laterali del capannone sono previsti canali asolati per il montaggio delle staffe per il kit mensola. Ripiano in PVC rinforzato largo 6 pollici con staffa e tappi terminali.

PL W bocznych pionowych kolumnach szopy znajdują się listwy szczelinowe do montażu wsporników zestawu półek. 6-calowa wzmocniona półka z PVC ze wspornikiem i zaślepkami.

RO Canalele cu fante sunt prevăzute în coloanele verticale laterale ale magaziei pentru a monta consolele pentru setul de rafturi. Raft din PVC armat cu lățime de 6 inch cu suport și capace de capăt.

BG Каналите с прорези са предвидени в страничните вертикални колони на навеса за монтиране на скобите за комплекта на рафта. 6-инчов подсилен PVC рафт със скоба и крайни капачки.

TR Raf kitinin braketlerini monte etmek için kulübenin yan dikey sütunlarında oluklu Kanallar bulunmaktadır. Braket ve uç kapaklı 6 inç genişliğinde güçlendirilmiş PVC raf.



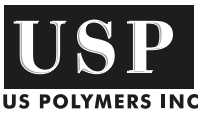

U.S. Polymers, Inc.
1057 S. Vail Ave
Montebello, CA 90640,
United States of America

www.duramaxbp.com